

Drug Development[®] & Delivery[®]

September 2019 Vol 19 No 6

www.drug-dev.com

Empowering Self-Administration

IN THIS ISSUE



INTERVIEW WITH
ELOXX PHARMA'S
CHAIRMAN & CEO

BOB WARD

ON-TARGET DELIVERY 16

Fabrice Navarro, PhD

DEVICE DESIGN 65

Pascal Dugand
Thomas Megard
Séverine Duband

THERANOSTICS 70

Eric Krenning, MD
Rachel Levine

MARKET NEWS & TRENDS 10

TECHNOLOGY & SERVICES SHOWCASE 61

The science & business of drug development in specialty pharma, biotechnology, and drug delivery



Daniel O'Connor
Arming the Immune System;
Turning Cold Tumors Hot



Cindy H. Dubin
Injection Devices:
Wearables,
Connectivity &
Patient-Centric
Designs Empower
Self-Administration



Megan Lan, MBA
Enabling Biologic
Drug Delivery of
Volumes Beyond
1 mL

Capsugel®

Lonza

Pharma & Biotech

Capsugel® Zephyr™

Dry-Powder Inhalation Capsule Portfolio

Made better. By science.™

Want to know more?
Visit www.capsugel.com



OXYCAPT™ Plastic Vial & Syringe

Multilayer Structure

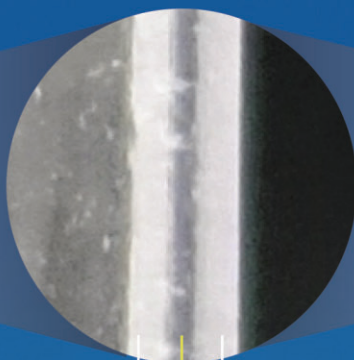

- Excellent Oxygen Barrier**
- High Water Vapor Barrier**
- Very Low Extractables**
- Low Protein Adsorption**
- Excellent Ultraviolet Barrier**
- High Break Resistance**
- High pH Stability**
- Silicone Oil Free Barrel**
- Pre-sterilized Vial & Syringe**
- Customizable**
- Suitable for Biologics**

Water Vapor Barrier Layer (COP)

Oxygen Barrier Layer (New Polymer)

Drug Contact Layer (COP)



MITSUBISHI GAS CHEMICAL

Mitsubishi Gas Chemical Company, Inc.

<https://www.mgc.co.jp/eng/products/abd/oxycapt.html>

Mitsubishi Gas Chemical America, Inc.

<http://www.mgc-a.com>

E-mail: nb3.pharmapackage@mgc.co.jp



**A new eBook is
Coming Soon**

Drug Development[®] & Delivery

September 2019 Vol 19 No 6

PUBLISHER/PRESIDENT

Ralph Vitaro
rvitaro@drug-dev.com

EXECUTIVE EDITORIAL DIRECTOR

Dan Marino, MSc
dmarino@drug-dev.com

CREATIVE DIRECTOR

Shalamar Q. Eigel

CONTROLLER

Debbie Carrillo

CONTRIBUTING EDITORS

Cindy H. Dubin
John A. Bermingham
Josef Bossart, PhD
Katheryn Symank

TECHNICAL OPERATIONS

Mark Newland

EDITORIAL SUPPORT

John Roy

ADMINISTRATIVE SUPPORT

Owen Stucy

Corporate/Editorial Office

219 Changebridge Road, Montville, NJ 07045
Tel: (973)299-1200
Fax: (973) 299-7937
www.drug-dev.com

Advertising Sales Offices

International

Ralph Vitaro
219 Changebridge Road
Montville, NJ 07045
Tel: (973) 299-1200
Fax: (973) 299-7937
E-mail: rvitaro@drug-dev.com

Global Sales & Marketing Director

John Kiesewetter
P.O. Box 8548
Eugene, OR 97408
Tel: (541) 338-0022
Fax: (541) 338-0044
jkiesewetter@drug-dev.com

Drug Development & Delivery

Analytical Testing

eBook
Analytical Testing
Edition
Summer 2019



Visit

www.drug-dev.com

for more info

All editorial submissions are handled with reasonable care, but the publishers assume no responsibility for the safety of artwork, photographs, or manuscripts. Every precaution is taken to ensure accuracy, but publishers cannot accept responsibility for the accuracy of information supplied herein or for any opinion expressed. Drug Development & Delivery (ISSN) 1537-2898 is published 9 times in 2019, January/February, March, April, May, June, July/August, September, October, and November/December by Drug Delivery Technology LLC, 219 Changebridge Road, Montville NJ 07045. Subscription rates: \$120.00 for 1 year in the United States, Canada, and Mexico. \$188.00 for 1 year outside the United States, Canada, and Mexico. All subscriptions are payable in US funds, drawn on US banks. Send payment to: Drug Development & Delivery LLC subscription Department, 219 Changebridge Road, Montville NJ 07045. Single copies (prepaid) \$20.00, US, Canada, and Mexico; \$25.00 in all other countries. Add \$5.00 per order for shipping and handling. Periodicals Postage Paid at Montville, NJ 07045-9998 and additional mailing offices. Postmaster: please send address changes to Drug Development & Delivery, 219 Changebridge Road, Montville NJ 07045. All rights reserved under the US International and Pan-American Copyright Conventions. All rights reserved. No part of this publication may be reproduced or transmitted in any form or by any means, electronic or mechanical, including by photocopy, recording, or information storage and retrieval system, without written permission from the publisher. Authorization to photocopy items for internal or personal use, or the internal or personal use of specific clients, is granted by Drug Development & Delivery for libraries and other users registered with the Copyright Clearance, 222 Rosewood Drive, Danvers, MA 01923; phone: (978) 750-8400, fax: (978) 750-4470.

Proud member of



LIQUID CAPTISOL®

Now offering Aseptic-filled Liquid Captisol.

Facilitate your drug discovery and development activities with Liquid Captisol. Liquid Captisol is a 50% aqueous concentrate of Captisol® (Betadex Sulfobutyl Ether Sodium USP/NF) that has been aseptic-filled into 250 mL plastic bottles. The product will help you to move quickly into phase solubility studies, formulation development or safety studies. Now quickly dilute to your desired concentration and determine solubility or dose preclinically. Captisol has been used extensively to provide improved solubility, stability, bioavailability and dosing of challenging ingredients. Liquid Captisol is protected under our all-aqueous patented process and included within our extensive safety database. Accelerate your drug discovery and development and order non-clinical grade Liquid Captisol.

CAPTISOL.com



Empowering Self-Administration

"The global self-injection devices market is expanding at a rapid pace due to high prevalence and incidence rate of chronic diseases, technological advancements, new product development and commercialization, and product differentiation strategies adopted by leading pharmaceutical companies worldwide. In terms of revenue, the global market was valued at \$3.7 billion in 2017 and is projected to reach \$11.3 billion by 2026."

p.22



Table of CONTENTS

ON-TARGET DELIVERY

16 **Lipid-Based System Introduces a Novel Approach for an HIV Vaccination**

Fabrice Navarro, PhD, summarizes recent disappointing clinical trial results for HIV vaccines and reports on CEA-Leti's new approach based on engineered lipid nanoparticles that deliver p24 (a viral protein that optimizes the CpG adjuvant's effect) with pinpoint accuracy.

SPECIAL FEATURE

22 **Injection Devices: Wearables, Connectivity, & Patient-Centric Designs Empower Self-Administration**

Contributor Cindy H. Dubin highlights the innovation in injection devices – from wearables to connectivity to varied dose administration – that have occurred in the past year.

INTRATUMORAL DELIVERY

42 **Arming the Immune System; Turning Cold Tumors Hot**

Daniel J. O'Connor believes a trigger mechanism that can turn cold tumors hot can help researchers set their focus on delivering potentially life-saving drugs directly to core of a cancerous tumor.

EXECUTIVE INTERVIEW

48 **Eloxx Pharmaceuticals: Developing Rare Disease Drugs for Nonsense Mutations**

Bob Ward, Chairman and CEO at Eloxx Pharmaceuticals, discusses nonsense mutations and how his company's goal is to bring safe and effective therapies to children and adults suffering from genetic diseases as quickly as possible.



METERED DOSING SYSTEMS

Multi-Site™

For Cosmetic Applications

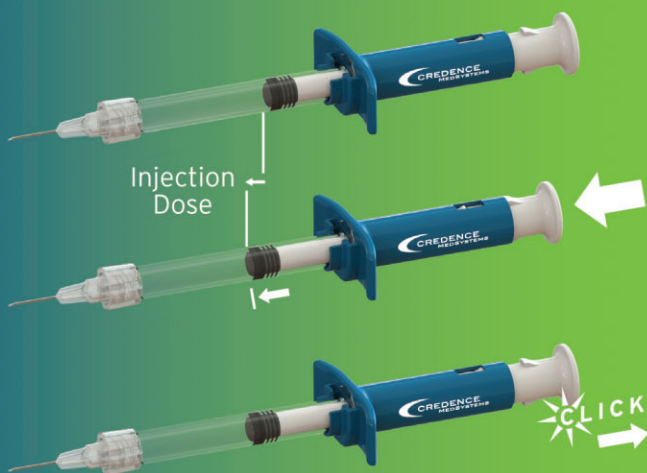

Multiple Controlled Injections
in One Procedure

Micro-Dose™

For Ocular Applications

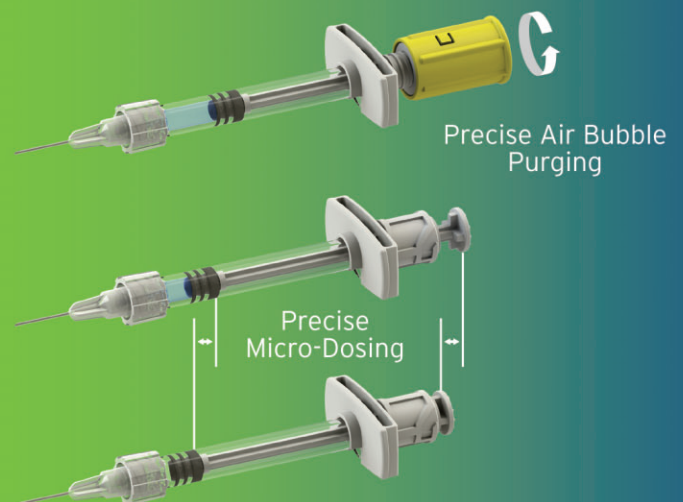

Precise Air Bubble Purging
and Micro-Dosing

IMPRESS | PRESERVE | PROTECT

Arming the Immune System

“Recognizing the shortcomings of high-dose IL-2, researchers are exploring novel delivery approaches that minimize the need to administer high doses of systemically delivered cytokines in order to improve safety while potentially enhancing effectiveness. In preclinical and clinical studies, intratumoral delivery of DNA-based interleukin-12 (IL-12-tavokinogene telseplasmid; tavo) by way of intratumoral, avoids the toxicity of systemic immune stimulation.”

p.42

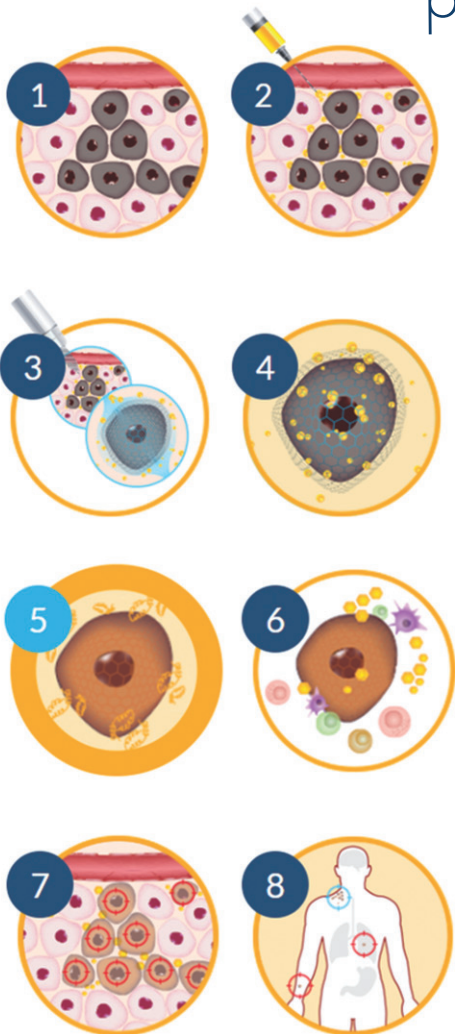

Table of CONTENTS

BIOLOGICS DELIVERY

52 Enabling Biologic Drug Delivery of Volumes Beyond 1 mL

Megan Lan, MBA, MA, and Patrick Le Gal say delivery system manufacturers need to use methodologies and tools to manage conflicting requirements and to offer delivery solutions that balance performance, robustness, and usability while delivering higher volume or viscosity biologics.

DEVICE DESIGN

65 Autoinjector Design Adjustment to Control Needle Insertion & Initial Injection Speed – Could This Positively Impact Drug Delivery?

Pascal Dugand, Thomas Megard, and Séverine Duband explain how controlling the needle insertion speed can reduce the shock on the prefilled syringe, which can reduce the risk of glass breakage, and will allow a smooth transition to syringe emptying.

THERANOSTICS

70 The Outlook for the Theranostic Radionuclide Approach to Neuroendocrine Tumors & Other Cancers

Eric P. Krenning, MD, PhD, and Rachel Levine provide a review of the evolution and development of theranostics, in general, citing the theranostic radionuclide approach to the management of neuroendocrine tumors to highlight this evolving modality.

DEPARTMENTS

Market News & Trends	10
Technology & Services Showcase	761



Why Yourway?



**The Only Truly Integrated
Premium Courier & Clinical
Packager.**

Yourway is The Biopharma Services Company changing the landscape of clinical supply chain solutions with a unique, integrated model. With 20+ years of clinical supply experience and 21 depot locations worldwide, We are the only truly integrated provider of clinical packaging, storage & distribution, and premium courier services.

Discover more at www.yourway.com

Cara Therapeutics Enters Commercial License Agreement With Enteris BioPharma

Cara Therapeutics, Inc. recently announced it has entered into a non-exclusive commercial license agreement with Enteris BioPharma, Inc. for oral formulation rights to Enteris' Peptelligence Technology.

"We are pleased to take another important step in advancing Oral KORSUVA as a potential novel treatment for chronic pruritus by entering into this commercial formulation license," said Derek Chalmers, PhD, DSc, President and Chief Executive Officer of Cara Therapeutics. "With three ongoing Phase 2 trials across a range of patient populations for whom pruritus remains a significant unmet need, we are now well positioned to continue Oral KORSUVA's development and potential future commercialization."

Under the terms of the License Agreement, Enteris granted Cara a non-exclusive license to its Peptelligence Technology to develop and commercialize Oral KORSUVA in any indication worldwide, excluding South Korea and Japan. Enteris will receive an upfront payment of \$8 million, including \$4 million in cash and \$4 million in Cara common stock. Enteris is also eligible to receive development, regulatory and tiered commercial milestone payments, as well as low, single-digit royalties based on net sales in the licensed territory. Cara retains the right to buy out the royalty obligation for a period of two years under prespecified condi-

tions.

Cara Therapeutics is a clinical-stage biopharmaceutical company focused on developing and commercializing new chemical entities designed to alleviate pruritus by selectively targeting peripheral kappa opioid receptors, or KORs. Cara is developing a novel and proprietary class of product candidates, led by KORSUVA (CR845/difelikefalin), a first-in-class KOR agonist that targets KORs located in the peripheral nervous system, and on immune cells. In a Phase 3 and two Phase 2 trials, KORSUVA (CR845/difelikefalin) Injection has demonstrated statistically significant reductions in itch intensity and concomitant improvement in pruritus-related quality of life measures in hemodialysis patients with moderate-to-severe chronic kidney disease-associated pruritus (CKD-aP), and is currently being investigated in Phase 3 trials in hemodialysis patients with CKD-aP. Oral KORSUVA is in Phase 2 trials for the treatment of pruritus in patients with chronic kidney disease, atopic dermatitis, and primary biliary cholangitis.

The FDA has conditionally accepted KORSUVA as the trade name for difelikefalin injection. CR845/difelikefalin is an investigational drug product and its safety and efficacy have not been fully evaluated by any regulatory authority.

Q BioMed & ChemVeda Announce Potential Chemotherapeutic Breakthrough

Q BioMed, Inc. and Chemveda Life Sciences recently announce the successful chemical synthesis of a unique natural compound that has shown remarkable efficacy as a potential chemotherapy for the treatment of liver cancer. This is a significant advancement for Q BioMed's portfolio asset Uttroside B and the compound's derivatives as a chemotherapeutic agent against, the most common form of liver cancer.

Additional confirmatory cell line efficacy data from current testing is expected to be completed in the next few weeks. The collaboration will advance the Q BioMed portfolio asset Uttroside B and its derivatives as a potential chemotherapeutic agent against hepatocellular carcinoma.

The compound was isolated and characterized from the leaves of *Solanum nigrum* Linn, a plant widely used in traditional medicines. In the Scientific Reports study, researchers showed that in animal models, Uttroside B was 10 times more cytotoxic to the HepG2 liver cancer cell line than sorafenib, the only drug approved by the FDA for liver cancer approved at the time and the current first line treatment for hepatocellular carcinoma. Sorafenib has been shown to increase survival by less than 3 months and has significant serious side effects, including hypertension, hemorrhage, and cardiovascular events including decreased blood flow to the heart and heart attacks.

Uttroside B significantly shrunk tumors in mice bearing human liver cancer xenografts. In addition, in preclinical experiments Uttroside B induced cytotoxicity in all liver cancer cell lines, and researchers were also able to confirm its biological safety, both by in vitro and in vivo studies.

Chemotherapeutic options for liver cancer are limited, and the prognosis of patients remains challenging. According to the Centers for Disease Control and Prevention, it is the second most common cause of cancer deaths worldwide, claiming approximately 750,000 lives each year. In the US, the American Cancer Society estimates that 42,000 people will be diagnosed with liver cancer in 2019 and that 32,000 will die from the disease this year. Liver cancer incidence has more than tripled since 1980 and deaths in the US have increased 56% since 2003.

Q BioMed Inc. is a biotech acceleration and commercial stage company. We are focused on licensing and acquiring undervalued biomedical assets in the healthcare sector. Q BioMed is dedicated to providing these target assets; strategic resources, developmental support, and expansion capital to ensure they meet their developmental potential, enabling them to provide products to patients in need .

Chemveda Life Sciences is a chemistry focused, aggressively growing, contract services partner helping global pharmaceutical & biotech companies, and academia improve their cost and timeline efficiencies over internal R&D. Chemveda is headquartered in Hyderabad, India and is creating a niche by providing cutting edge solutions ranging from highly exploratory discovery chemistry to drug product development across multiple chemistry classes. Chemveda's team of over 200 vastly qualified scientists is supported by its significant investments in client oriented facilities, systems and processes defined on the guiding principles of quality, safety and compliance.



DDL is an ISO 17025 accredited laboratory



MEDICAL DEVICE + PHARMA

A Reputation for Extraordinary Packaging, Product and Materials Testing.

DDL has nearly 30 years of first-hand experience navigating complex testing standards and regulations for medical device and pharma products. Our reliable quality, responsive attention, and on-schedule completion for packaging, product and materials testing secure confidence in performance and safety while achieving regulatory compliance.

TESTING EXPERTISE

- Packaging and Materials
- Medical Devices
- Combination Products

**NOW OFFERING
CCIT TESTING**

Partner with us and gain a reliable testing expert at your side! Visit us at DDLtesting.com or call us at **1-800-229-4235**

Minnesota | California | New Jersey

AC Immune Announces Research Collaboration With University of Pennsylvania

AC Immune SA recently announced a research partnership with leading scientists in the Perelman School of Medicine at the University of Pennsylvania (Penn) focused on studying the pathological mechanisms of TDP-43 misfolding and aggregation.

TDP-43, the transactive response (TAR) DNA binding protein, is a transcription factor found in most human tissues. It is a recently identified target of growing interest for neuroOrphan indications such as frontotemporal lobar degeneration (FTLD) and amyotrophic lateral sclerosis (ALS). It also plays an important role in other significant neurodegenerative indications such as Alzheimer's disease (AD).

The collaboration is aimed at deciphering the governing principles of how pathological forms of TDP-43 spread from neuron to neuron, leading to a better understanding of the TDP-43 pathologies in order to support the Company's mission to develop novel therapeutic and diagnostic approaches against FTLD and other neurodegenerative diseases.

AC Immune will contribute a two-year research grant to the laboratory of Dr. John Trojanowski and Dr. Virginia M.-Y. Lee. Dr. Trojanowski's research focuses on neurodegeneration and has led to the novel view that major disease-related proteins including Tau, alpha-synuclein and TDP-43, are co-deposited in most neurodegenerative diseases and how these copathologies impact the clinical representation of these diseases. Dr. Lee is a world-renowned leader in research on Tau, alpha-synuclein and the

Abeta precursor protein, studying their pathobiological roles in neurodegenerative diseases.

Prof. Andrea Pfeifer, CEO of AC Immune SA, commented "We are very proud to be working with Penn and Dr. Trojanowski and Dr. Lee, two very well-respected experts in neurodegenerative diseases. The field is still investigating the precise causes of neurodegenerative diseases and how to prevent, treat and even cure them, including neuroOrphan indications such as FTLD. Increasing our knowledge of the role of TDP-43 in disease pathology will mark valuable progress in this effort. AC Immune has generated several antibodies with unique binding profiles to TDP-43, and we are looking forward to results from preclinical proof-of-concept studies in Q3 2019."

AC Immune SA is a Nasdaq-listed clinical-stage biopharmaceutical company, which aims to become a global leader in precision medicine for neurodegenerative diseases. The Company is utilizing two proprietary discovery platforms, SupraAntigen and Morphomer, to design, discover and develop small molecule and biological therapeutics as well as diagnostic products intended to diagnose, prevent and modify neurodegenerative diseases caused by misfolding proteins. The Company's pipeline features nine therapeutic and three diagnostic product candidates, with five currently in clinical trials. It has collaborations with major pharmaceutical companies including Roche/Genentech, Eli Lilly and Janssen Pharmaceuticals Inc.

CureVac Enters Exclusive Collaborative Research Agreement

CureVac AG recently announced it has entered into a Collaborative Research Agreement with Yale University for discovery research into mRNA-based pulmonary therapeutic candidates.

The exclusive CRA covers the development of an undisclosed number of novel mRNA-based candidates for pulmonary diseases. Under terms of the CRA, the Yale University team, led by Geoff Chupp, MD, will perform discovery research on targets related to pulmonary diseases and present therapeutic candidates to CureVac for preclinical and subsequent clinical development. CureVac will provide all funding for the discovery research and retains the option to acquire any rights regarding the candidates.

"We're delighted to have the opportunity to partner with CureVac to work on what we hope will be the next generation of therapeutics for patients with severe respiratory disease," said John Puziss, PhD, the Director of Business Development in Yale's Office of Cooperative Research.

Dr. Chupp added, "mRNA therapeutics are at the forefront of drug development and CureVac is a leader in the field. We are very excited about the opportunity to merge our expertise in genomics of lung disease with CureVac's expertise in mRNA therapeutic development to develop novel therapeutics for lung disease. We look forward to a fruitful collaboration."

"We are honored to partner with the Yale team, which is performing cutting edge discovery research in the pulmonary field,"

said Dan Menichella, CEO of CureVac. "CureVac's next generation mRNA delivery vehicle, the CureVac Carrier Molecule (CVCM), can reach targets in the lung and other organs and is well suited for repeated administration. We look forward to uncovering potential new therapeutic candidates with Yale University to help provide solutions to those with the greatest medical need."

CureVac is a leading company in the field of messenger RNA (mRNA) technology with more than 19 years' expertise in handling and optimizing this versatile molecule for medical purposes. The principle of CureVac's proprietary technology is the use of mRNA as a data carrier to instruct the human body to produce its own proteins capable of fighting a wide range of diseases. The company applies its technologies for the development of cancer therapies, antibody therapies, the treatment of rare diseases, and prophylactic vaccines.

To date, CureVac has received approximately \$420 million (≈400 million) in equity investments, including significant investments from SAP founder Dietmar Hopp's dievini and the Bill & Melinda Gates Foundation. CureVac has also entered into collaborations with multinational corporations and organizations, including Boehringer Ingelheim, Eli Lilly & Co, CRISPR Therapeutics, the Bill & Melinda Gates Foundation, and others. For more information, please visit www.curevac.com or follow us on Twitter at @CureVacAG.

Saama & Comprehend to Form Preeminent Clinical Analytics Platform Company

Saama Technologies, Inc. recently announced it has signed a definitive agreement to acquire Comprehend Systems, Inc. This agreement combines Saama and Comprehend's respective industry positions as leading clinical data analytics companies. Together, Saama and Comprehend will deploy and evolve their complementary, best-in-class clinical analytics platforms. This agreement creates an opportunity to increase their combined market share, as well as expand their existing partner ecosystems and deliver on a mutual commitment to accelerate clinical development towards unmet patient needs.

"Our combined forces create an exciting, enhanced suite of complementary capabilities to empower life sciences companies to further accelerate clinical development and meet the therapeutic needs of patients around the world, challenge the status quo, and achieve clinical insights in days versus months," said Suresh Katta, Founder and Chairman of Saama. "Combining Saama and Comprehend elevates our ability to do what we do best – innovate cutting-edge, AI-powered clinical development solutions and software that empower biopharma to facilitate more rapid drug development."

"The Comprehend-Saama transaction creates a data analytics powerhouse with a singular vision of improving human health through the application of AI-powered solutions for actionable clinical trial insights," said Rick Morrison, Founder and Chairman of Comprehend. "The combined 30-plus years of experience of these two companies as data analytics innovators provides exciting opportunities to speed biopharma's development of new therapeutics and to have broader industry reach."

"Saama and Comprehend offer life sciences companies and

patient-focused organizations the ability to access and optimize a combined ecosystem of unique, state-of-the-art analytics solutions and visualization tools that enable the re-imagining of clinical development and the realization of precision medicine," said Rebecca Daniels Kush, PhD, founder of the Clinical Data Interchange Standards Consortium (CDISC), and member of Saama's Clinical Board of Advisors.

Saama Technologies is the advanced clinical data and analytics company, unleashing wisdom from data to deliver better actionable business outcomes for the life sciences industry. Saama's unified, AI-driven clinical data analytics cloud platform seamlessly integrates, curates, and animates unlimited sources of structured, unstructured, and real-world data to deliver actionable insights across all therapeutic areas. The award-winning platform gives unprecedented real-time visibility into clinical data, enabling sponsors to file New Drug Applications (NDAs) more efficiently to bring drugs to market faster and at lower costs. For more information, visit <https://www.saama.com>.

Comprehend provides a suite of cloud applications and consulting services that dramatically improve the clinical trial process. Our solutions deliver actionable risk and performance insights across studies, systems, sites, and vendors. By using elements of our Clinical Intelligence Platform to unify, monitor, and analyze data across all sources, sponsors and CROs alike are able to reduce risk, achieve milestones on time, and stay within budget. As a trusted partner, Comprehend helps speed the time to quality results. For more information, visit <https://www.comprehend.com>.



MECHATRONICS FOR LIFE THE CONNECTED DRUG DELIVERY PLATFORM



LARGE VOLUME
INJECTION



AUTOMATIC
RECONSTITUTION
INJECTION



DUAL CARTRIDGE
INJECTION



CONNECTIVITY

FROM CLINICAL
TRIALS TO LIFE CYCLE
MANAGEMENT

medical.sonceboz.com

FROM MIND TO MOTION

Ivy Brain Tumor Center & Salaris Pharmaceuticals Launch Collaborative Partnership

The Ivy Brain Tumor Center at the Barrow Neurological Institute and Salaris Pharmaceuticals, Inc. recently announced a collaborative partnership to test Salaris' therapeutic candidate, Seclidemstat, for the treatment of glioblastoma. The organizations will launch what they believe is the most comprehensive preclinical study to date, evaluating the effect of targeting LSD1 (lysine-specific histone demethylase 1A), a key enzyme that has increased expression in tumors of brain cancer patients.

Seclidemstat is a reversible LSD1 inhibitor that works by inhibiting LSD1's enzymatic and protein-scaffolding functions. It is currently being tested by Salaris in a Phase 1 study for refractory or relapsed Ewing's sarcoma and a Phase 1 study for Advanced Solid Tumors. Seclidemstat is among the most clinically advanced reversible LSD1 inhibitors in development, and its potential effect on glioblastoma represents a promising new therapeutic treatment option.

"Seclidemstat is highly differentiated LSD1 inhibitor with unique properties that may enable efficacy in a broader range of cancer types. Seclidemstat and/or its analogs have shown the potential for synergies with chemotherapies and other targeted agents. This gives us hope that Seclidemstat may be effective in treating a number of aggressive cancers, including glioblastoma," said Dr. Nader Sanai, Director of the Ivy Brain Tumor Center. "Our shared goal with Salaris is to address the lag in new drug development for malignant brain tumors by accelerating early-phase clinical trials for first-in-class agents like Seclidemstat."

The Ivy Brain Tumor Center's advanced preclinical capabili-

ties include well-characterized patient-derived xenograft animal models and state-of-the-art pharmacokinetics and pharmacodynamics core facilities. A key component to this latest endeavor will be to leverage the Ivy Center's core capabilities in collaboration with Salaris to perform in-house survival studies, advanced animal imaging, toxicology assessment, and in vivo pharmacometabolic analyses.

Should the preclinical phase provide sufficient evidence for positive drug effects, the program will move to the subsequent clinical evaluation of Seclidemstat. This will take place within the context of a Phase 0 clinical trial, in which researchers will quickly learn if the new regimen is having the desired impact on a patient's individual tumor.

"Salaris is well positioned and highly-motivated to provide a new therapeutic option for a number of cancers with high unmet medical need," said David Arthur, President and Chief Executive Officer of Salaris Pharmaceuticals. "We are inspired by the Ivy Brain Tumor Center's unwavering commitment to pursuing advances in glioblastoma treatment and look forward to this creative and vital research partnership."

Ivy Brain Tumor Center at the Barrow Neurological Institute in Phoenix, AZ, is a non-profit translational research program that employs a bold, early phase clinical trials strategy to identify new treatments for aggressive brain tumors, including glioblastoma. Salaris Pharmaceuticals, Inc. is a clinical-stage oncology company targeting the epigenetic causes of cancers and is developing treatments for patients that need them the most.

MyoKardia Begins Dosing in Phase 1 Clinical Study

MyoKardia, Inc. recently announced it has dosed the first subjects in a Phase 1 clinical study of MYK-224, a small molecule candidate being developed for the treatment of hypertrophic cardiomyopathy (HCM). HCM is a progressive disease in which the excessive contraction of the heart muscle and reduced ability of the left ventricle to fill can lead to the development of debilitating symptoms and cardiac dysfunction, ranging from shortness of breath and reduced exercise capacity to heart failure and sudden cardiac arrest. MYK-224 selectively targets cardiac myosin, the heart's motor protein, with the aim of normalizing contractility and filling.

"The initiation of our Phase 1 clinical study of MYK-224 in healthy volunteers allows us to further expand our disease-area leadership in hypertrophic cardiomyopathy," said June Lee, MD, MyoKardia's Chief Development Officer. "Patients experiencing symptoms of HCM currently lack adequate pharmacologic treatment options. Advancing a second HCM candidate in our portfolio is consistent with our focus on, and commitment to, providing HCM patients with new therapies that target the underlying cause of their disease."

The Phase 1 clinical trial is intended to evaluate the safety, tolerability and pharmacokinetics of MYK-224. The trial is a randomized, placebo-controlled, single and multiple-ascending dose study that will enroll adult healthy volunteers into cohorts of eight, randomized 3:1 to MYK-224 or placebo. Pharmacodynamic effects on cardiac function and dimensions will also be assessed using echocardiography. MyoKardia anticipates providing topline results from the Phase 1 study in mid-2020.

MYK-224 is designed with distinct physicochemical properties that may enable certain dosing advantages for some HCM patients. In preclinical studies, MYK-224 was shown to attenuate hyperactive myosin proteins containing known pathogenic HCM mutations. Additionally, MYK-224 modulates cardiac myosin without affecting myosin-actin cross-bridge kinetics or altering calcium homeostasis.

MYK-224 joins MyoKardia's growing portfolio of therapeutic candidates targeting sarcomeric proteins of the heart muscle to address cardiovascular diseases of excessive or insufficient contraction or impaired relaxation. MyoKardia's lead clinical-stage therapeutic candidate for HCM, mavacamten, is currently being studied in the Phase 3 EXPLORER-HCM clinical trial for the treatment of obstructive HCM, where topline data are expected in Q2 2020, and in the Phase 2 MAVERICK-HCM clinical trial in non-obstructive HCM, where topline data are expected in Q4 of this year.

MyoKardia is a clinical-stage biopharmaceutical company pioneering a precision medicine approach to discover, develop and commercialize targeted therapies for the treatment of serious cardiovascular diseases. MyoKardia's initial focus is on the development of small molecule therapeutics aimed at the muscle proteins of the heart that modulate cardiac muscle contraction and underlying diseases of systolic and diastolic dysfunction. MyoKardia applies a precision medicine approach to develop its therapeutic candidates for patient populations with shared characteristics, such as causal genetic mutations or disease subtypes.

Mustang Bio Announces \$9.28-Million Grant to Fund Phase 1 Trial

Mustang Bio, Inc. recently announced that City of Hope has received a \$9.28-million grant from the California Institute for Regenerative Medicine (CIRM) to fund an ongoing Phase 1 clinical trial of MB-103 (HER2-specific CAR T cells) for the treatment of HER2-positive breast cancer with brain metastases. City of Hope patents covering the HER2 CAR were licensed to Mustang Bio in 2017.

The City of Hope research team led by Saul Priceman, PhD, Assistant Professor in the Department of Hematology & Hematopoietic Cell Transplantation, along with the clinical lead Jana Portnow, MD, Associate Clinical Professor in the Department of Medical Oncology & Therapeutics Research, will use the funds to support the Phase 1 trial. The trial is expected to enroll 21 patients at City of Hope. The trial's primary objective is to determine the safety and recommended Phase 2 dosing of intraventricular delivery of HER2-specific CAR T cells. Secondary objectives include assessing cerebrospinal fluid (CSF) and peripheral blood for HER2-CAR T cell persistence and endogenous immune system activation, describing changes in cytokine levels in the CSF and peripheral blood and describing changes in circulating tumor cells in the CSF.

According to the American Cancer Society, about 1 in 5 patients with breast cancer have HER2-positive cancer cells. Nearly half of patients with HER2-positive breast cancer ultimately develop brain metastases.

Manuel Litchman, MD, President and Chief Executive Officer

of Mustang, said "We congratulate City of Hope on receipt of this prestigious grant to fund the Phase 1 MB-103 trial. When infused into the ventricular system through the brain, MB-103 has the potential to target and destroy HER2-expressing tumors that metastasized from breast cancer. We look forward to continuing to work with the City of Hope team to advance this program and bring hope to patients with breast-cancer-related brain metastases, who have very few treatment options available."

Mustang Bio, Inc. is a clinical-stage biopharmaceutical company focused on translating today's medical breakthroughs in cell and gene therapies into potential cures for hematologic cancers, solid tumors and rare genetic diseases. Mustang aims to acquire rights to these technologies by licensing or otherwise acquiring an ownership interest, to fund research and development, and to outlicense or bring the technologies to market. Mustang has partnered with top medical institutions to advance the development of CAR T and CRISPR/Cas9-enhanced CAR T therapies across multiple cancers, as well as a lentiviral gene therapy for X-SCID. Mustang is registered under the Securities Exchange Act of 1934, as amended, and files periodic reports with the U.S. Securities and Exchange Commission. Mustang was founded by Fortress Biotech, Inc. (NASDAQ: FBIO). For more information, visit www.mustangbio.com. Additional information on the Phase 1 trial can be found on www.ClinicalTrials.gov using identifier NCT03696030.



THE DIFFERENCE OF **ONE** DRUG DELIVERED

WITH A GLOBAL LEADER IN PREFILLABLE DELIVERY SYSTEMS. BD partners closely with leading pharmaceutical companies to support their success from drug development to launch and beyond. With a broad portfolio of innovative drug delivery systems, a global perspective and regulatory insights, a BD Medical – Pharmaceutical Systems team can partner with you to match the optimal solutions to your product. In addition to prefillable syringes, our technologies include self-injection systems, safety and shielding solutions—which we can customize and develop to meet your precise technical requirements and the demands of your business. You can also count on our depth of regulatory knowledge, product development, medical expertise and responsive support. Discover the confidence of working with the right partner. **Discover the difference of BD.**

Learn more at bd.com



BD

Advancing the
world of health

ON-TARGET DELIVERY

Lipid-Based System Introduces a Novel Approach for an HIV Vaccination

By: Fabrice Navarro, PhD

INTRODUCTION

HIV is one of the deadliest pandemics of modern times, having caused 35 million deaths around the world. While researchers and clinical workers have identified antigens and antibodies necessary to validate diagnosis and have developed antiviral drugs to suppress HIV replication, we still do not have an effective means to prevent and fight the infection. Immunological obstacles are a significant barrier to designing an efficient HIV vaccine. In addition, clinical trial failures have demonstrated the need for novel approaches to identify relevant antigens and adjuvants, as well as for better delivery systems. Innovation based on engineered nanoparticles (NPs) can help overcome these obstacles. A team from CEA-Leti recently demonstrated a concept of an HIV vaccine that enhances an adjuvant's effect, delivered with pinpoint accuracy in the body. This nanoparticulate system is made of bio-assimilable lipids, called Lipidots™. The following will summarize the immunological obstacles, as well as previous trial failures and explain how the Lipidot technology points the way toward an effective new HIV vaccine.

PREVIOUS "DISAPPOINTING RESULTS"

New HIV vaccine candidates face immunological obstacles, mainly the poor immunogenicity of HIV antigens and the lack of a potent protective immunity, which can be overcome only by introducing innovation in the design of vaccine formulations. Until now, only three prophylactic vaccine candidates have completed the efficacy trials of Phases 2b and 3. The results of these trials

were unexpectedly disappointing. AIDSVAX, which was based on the HIV envelope protein gp120 and an alum adjuvant, failed to effectively protect against HIV infection, even though it triggered the production of high levels of autologous neutralizing antibodies in humans. These antibodies bind and neutralize the biological activity of the antigens.¹ The subsequent STEP/PHAM-BILI trials tested the protective capacity of three injections of adenovirus 5 vector and viral vector, delivering Gag, Pol, and Nef HIV antigens. This strategy resulted in an increased risk of HIV infection in vaccinated individuals with preexisting anti adenovirus immunity.^{2,4} In addition, the RV144 trial combining AIDSVAX with a canarypox-based recombinant vector reduced HIV acquisition risk only by about 31%.⁵ This effect is considered insufficient to impact the HIV epidemic, but it significantly helped to unravel the immune-correlates of protection.

ANTIGEN DELIVERY SYSTEMS ARE CRITICAL

Although broadly neutralizing antibodies (bNAb) represent one of the most powerful approaches to control infection and block transmission in non-human primate (NHP) models, no vaccine has yet been produced that can elicit significant and sustained levels of NAb. In addition, future vaccines should induce cytotoxic CD8+ T-cell responses, to allow clearance of infected cells, while healthy CD4+ T cells orchestrate appropriate immune responses. In this context, antigen delivery systems are key to enhancing immune responses to sub-unit vaccines. In particular, viral particles or virus-like particles (VLPs) are made of self-assembled viral proteins and mimic the morphology of a given pathogen.



Comprehensive
support for your
injectables

CPhI Worldwide

Meet our
experts at Booth
#12.0D73

For over 35 years, Vetter has been a trusted partner in injectables manufacturing for pharmaceutical and biotech companies around the world. Our deep expertise enables us to integrate with your team to design and implement a personalized plan for success in a shifting global marketplace. Our strategic partnership includes:

- Customized clinical and commercial manufacturing services for your product throughout its lifecycle
- Deep and comprehensive technical, analytical, and regulatory subject matter expertise
- Proven manufacturing processes that are flexible, efficient, and scalable
- Filling and packaging capabilities that utilize the latest technology to meet international market demands

www.vetter-pharma.com



Answers that work

Furthermore, VLPs have highly conserved structures called pathogen-associated molecular patterns (PAMP) that can stimulate the immune system, but also lead to pathogen-induced inflammation and associated tissue damage. Despite their excellent immunostimulating properties, the cost of producing VLPs remains the major issue of these antigen delivery systems.

In this context, an alternative to viral particles, synthetic and engineered delivery systems are getting more attention. Their compositions are well known, meaning better control of their safety. Moreover, they are cheaper and simpler to produce in large scale compared to particles of biological origin. They stand out primarily because of their targeting properties: nanoparticles with a diameter below 150 nm are able to both enter lymph vessels where they will ultimately reach lymph nodes, and be internalized by antigen-presenting cells (APCs). Delivering antigens to APCs is a key step in triggering antigen-specific immune responses. This is because of their capacity to initiate the activation of specific T lymphocytes (TL) and to regulate their functions by the secretion of cytokines. Nanoparticle carriers may also prevent antigen proteolytic degradation, allow the co-delivery of antigens and immune-stimulants, and allow cross-presentation by dendritic cells (DC). Many different types and sizes of vectors have been explored. In particular, the lipid nanoparticles Lipidots developed by CEA-Leti, are of considerable interest because they fulfill all the aforementioned criteria: they are smaller than 100 nm, they are really stable even in biological media, and they can reach the lymph nodes after their administration where they are taken up by APCs.⁶

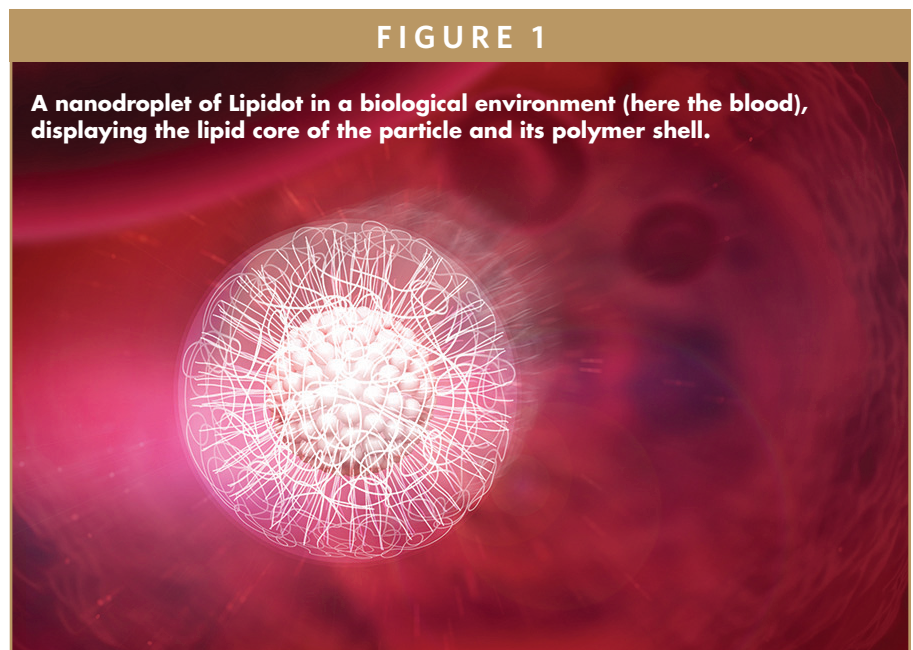

A "COCKTAIL OF LIPIDOTS"

To further promote antigen-associated immune responses, immunostimulatory molecules can be transported by these types of particulate systems, with the aim of delivering a "danger" signal to APCs in combination with the antigen, for optimal activation of these immune cells. In a recent study, CEA-Leti demonstrated the potential of using Lipidots as a versatile vaccine delivery system for inducing potent immune responses against the HIV-1 p24 antigen, which is recognized as a poor immunogen.⁷ This antigen was associated with the CpG adjuvant known for its immunostimulatory properties. To our knowledge, this is the first immunological study using lipid nanoparticles to deliver both p24 and an immunostimulant and reporting a very high induction of T-cell response. Importantly, in mice immunized with a "cocktail of Lipidots," some particles bearing the p24 antigen and others, the CpG, high levels of antigen-specific antibodies of different subclasses (IgG1, IgG2a, IgA), were measured in the blood. Activation of CD8 T lymphocytes by these

lipid-nanocarrier formulations was also highly significant as they are the main effectors of the cytotoxic response needed to clear infected cells.

The impact on the resulting cellular activation demonstrated Lipidots's value and potential. The combined results showed the advantages of using these nanoparticles to deliver both antigen and immunostimulant, because the combination induced complex and potent immune responses. These effects have also been demonstrated in the model of NHPs, the best animal model for studying HIV. NHPs present an immune system very similar to humans. In terms of perspectives, lipid nanoparticles developed by CEA-Leti can be associated with other rational HIV antigens, such as envelope glycoproteins gp120 or gp41. The goal of such a multi-antigen vaccine formulation is to induce multi-targeted immune responses, namely Env-specific broadly neutralizing antibodies and p24 specific cytotoxic responses, for protection against HIV.

THE SHL PERSPECTIVE

EMPOWERING TRANSFORMATION

Enhancing drug delivery with advanced self-injection solutions

Learn more at the 2019 PDA Universe of Pre-filled Syringes & Injection Devices
Oct 22-23 | Gothenburg, Sweden | Booth F45-46 & F47



30th
ANNIVERSARY

30 years in the making and beyond



FIGURE 2

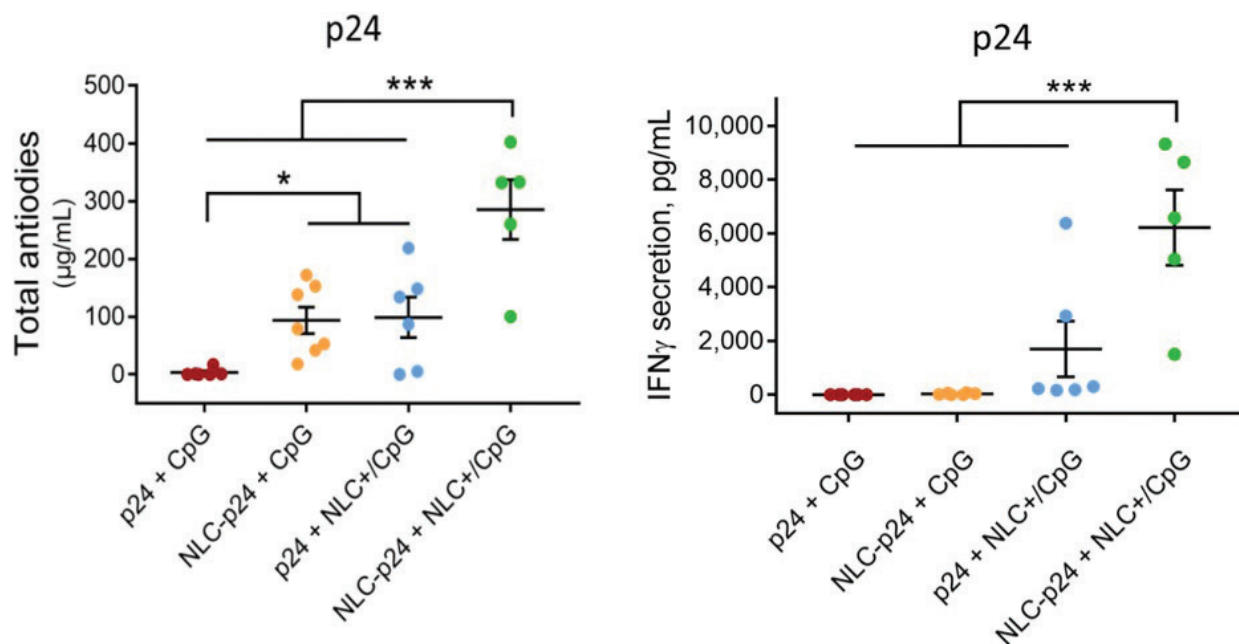

Immunogenic properties of lipid nanoparticles used as delivery systems for antigens (HIV p24) associated with immunostimulant CpG vectorized or not (CpG versus NLC+/CpG).

Left: specific antibody response measured in the blood of mice.

Right: IFN γ secretion from T lymphocytes isolated from mice having received the formulations. IFN γ is a biomarker representative of the cellular immune responses. Each point represents an individual mouse - horizontal bars represent the mean for the group, and vertical bars indicate the standard error of the mean. Data were compared between groups using a 1-way ANOVA test followed by Fisher's-protected least-significant difference test. *p<0.05; *** p<0.001.

FROM LAB TO PRODUCTION

Lipidots are manufactured using ultrasonication on a millileter scale. A mid-scale production process, including a high-pressure homogenization process and purified by tangential flow filtration in a controlled environment (endotoxin free), was set up in 2016 to translate Lipidots' potential efficacy to clinical utility. Furthermore, an extensive pre-clinical characterization was initiated with the development and validation of a large panel of analytical and physico-chemical methods in CEA and in collaboration with the European Nanomedicine Characterisation Laboratory (EUNCL). Currently, after production: 1) the endotoxin contamination level (LAL assay), 2) the size and polydispersity (batch mode DLS), and 3) the total drug-loading content (HPLC-fluorescence) of

each batch are measured. This pre-screening step is followed by the combination of complementary high-resolution techniques, including liquid chromatography (UPLC-ELSD) or mass spectroscopy. It also includes asymmetric field-flow fractionation coupled to light-scattering detectors and electron transmission microscopy to assess drug loading, physical stability, and chemical stability in simple and complex media.

The Lipidot process is quite stable, and research has proven its efficiency by HPH for the manufacturing of small batches up to 300 ml. To offer full production, CEA-Leti is working with V-Nano, a contract development and manufacturing organization, for manufacturing injectable batches of nano-formulations up to 60 L. To validate the industrial scale up, we need first to manufacture Lipidot batches up to a few liters. CEA-Leti will work with a CEA

Tech platform in Labège, France, to develop a new Lipidot scale-up infrastructure, including equipment for manufacturing nanoformulation batches up to 3 L. This new infrastructure will be 100% operational in early 2020 and open to both CEA institutes and V-Nano's partners.

BEYOND LIPIDS: A DIVERSITY OF NANOMEDICINE APPLICATIONS

The Lipidot technology is one example of the beneficial role that innovative therapeutic and diagnostic opportunities can play in medicine. There is a growing number of R&D projects aiming at developing novel diagnostic and/or therapeutic concepts based on nanotechnology applications, and a growing number of new nanotechnology-based products are reach-

ing the European market. Most of the currently approved nano-enabled products are based on conventional active substances that already have been approved. The relevant platforms may contain a nanoparticle (such as liposome or polymer) with a bound or encapsulated active substance or may be formed directly from the constituent drug in a nano form. The remainder of investigational nanomedicines demonstrates a trend toward agents using micelles, as well as the introduction of formulations using dendrimers. Among the approved products on the market, the main nanotechnology platforms include: nanocrystals, polymer-protein conjugates, amino-acid based polymers, biodegradable polymers, nano-emulsions, liposomes, iron-carbohydrate complexes in a colloidal suspension, and virosomes.

In all cases, the main advantages are related to the improved pharmacokinetic (PK) properties, such as:

- Prolonged stability and blood circulation
- Improved transport across biological barriers
- Preferential distribution within the body
- Controlled and site-specific release
- Improved solubility of hydrophobic drugs.

These properties help boost efficacy while reducing the dosage and limiting the risk of side effects.

SUMMARY

To go further in the design of innovative vaccine formulations, we have to apply our concept of delivering vaccine

components by using Lipidot technology with a range of antigens. In particular, in the context of HIV, we have to consider HIV antigens from the viral envelope and the capsid to elicit broadly neutralizing antibodies, as well as potent cellular response (CD8+ T cells). The correlate of protection must be demonstrated in relevant animal models before entering the early phases of human clinical trials. In parallel to this clinical translation, we are addressing the industrialization phase of our particles by developing and transferring our manufacturing processes at the large scale to industrial partners for the production of controlled clinical batches made in GMP conditions. In addition, we anticipate writing a clinical development plan with the help of experts in the field to speed up the clinical validation and approval by regulatory agencies. ♦

REFERENCES

1. Gilbert, P. B. et al. Correlation between immunologic responses to a recombinant glycoprotein 120 vaccine and incidence of HIV-1 infection in a phase 3 HIV-1 preventive vaccine trial. *J. Infect. Dis.* 191, 666–677 (2005).
2. Buchbinder, S. P. et al. Efficacy assessment of a cell-mediated immunity HIV-1 vaccine (the Step Study): a double-blind, randomised, placebo-controlled, test-of-concept trial. *Lancet* 372, 1881–1893 (2008).
3. McElrath, M. J. et al. HIV-1 vaccine-induced immunity in the test-of-concept Step Study: a case-cohort analysis. *Lancet* 372, 1894–1905 (2008).
4. Moodie, Z. et al. Continued follow-up of phambili phase 2b randomized HIV-1 vaccine trial participants supports increased HIV-1 acquisition among vaccinated men. *PLoS ONE* 10, e0137666 (2015).
5. Haynes, B. F. et al. Immune-correlates analysis of an HIV-1 vaccine efficacy trial. *N. Engl. J. Med.* 366, 1275–1286 (2012).
6. Courant T, Bayon E, Reynaud-Dougier HL,

Villiers C, Menneteau M, Marche PN, et al. Tailoring nanostructured lipid carriers for the delivery of protein antigens: Physicochemical properties versus immunogenicity studies. *Biomaterials.* 2017;136:29-42.

7. Bayon E, Morlieras J, Dereuddre-Bosquet N, Gonon A, Gosse L, Courant T, et al. Overcoming immunogenicity issues of HIV p24 antigen by the use of innovative nanostructured lipid carriers as delivery systems: evidences in mice and non-human primates. *Npj Vaccines.* 2018;3.

To view this issue and all back issues online, please visit www.drug-dev.com.

BIOGRAPHY



Dr. Fabrice Navarro began his career in nanomedicine at CEA in a post-doctoral position at CEA Tech, where he worked on in vivo imaging using lipid nanoparticles. He joined CEA-Leti as a researcher, working on various nanomedicine projects as principal investigator, and leading a small research group. In 2016, he was named head of a lab working on the design and validation of new diagnostic tools or therapeutic strategies using micro- and nanotechnologies. Dr. Navarro also heads CEA Tech's microfluidic systems and bioengineering lab (~ 30 scientists). With more than 10 patents, he is co-author of more than 35 publications and more than 30 reviewed proceedings. He earned his PhD in Molecular and Cell Biology, Physiology and Neurosciences in 2006 from the University Claude Bernard of Lyon, on the study of molecular and cellular mechanisms of neuro inflammation in pathogenesis of epilepsy.

SPECIAL FEATURE

Injection Devices: Wearables, Connectivity & Patient-Centric Designs Empower Self-Administration

By: Cindy H. Dubin, Contributor

The global self-injection devices market is expanding at a rapid pace due to high prevalence and incidence rate of chronic diseases, technological advancements, new product development and commercialization, and product differentiation strategies adopted by leading pharmaceutical companies worldwide. In terms of revenue, the global market was valued at \$3.7 billion in 2017 and is projected to reach \$11.3 billion by 2026.¹

“The high numbers of new injectable drugs projected to reach the market in the coming years, as well as the trend to move therapies from clinics into home settings to save costs and provide more convenience for patients means increasing demands for injection devices,” says Hans Jensen, Global Business Development Director, Consort Medical, Bespak Drug Delivery Devices.

The global self-injection devices market is also driven by a significant rise in demand for home health care, owing to low cost of treatment and improvements in overall patient experience.

The ability of self-administration is a key factor fueling demand for pen injectors.

The pen injectors segment held a significant share of 67.6% of the market in 2017 and research indicates that it is likely to be the leading product segment, owing to the applications in diabetes, easy availability, and low cost, according to a report from Transparency Market Research.

Technological advancements in self-injection devices, especially in autoinjectors and wearable injectors, for the administration of high viscosity and large-volume drugs represents a potential business development opportunity for leading players. Reports suggest that the wearable injectors segment is projected to expand at a CAGR of 20% between 2018 and 2026.¹



The D-Flex connected pen system from Haselmeier.

“Traditional spring-based autoinjectors have previously been sufficient to deliver the drugs being developed, however many biologics by nature need higher doses to have an effect, which leads to higher viscosities and/or higher volumes to be delivered,” says Mr. Jensen. “Furthermore, others are working on viscous long-acting formulations to decrease frequency of injections, thereby increasing patient convenience. Finally, a number of drugs initially developed for IV administration in clinics are being re-formulated to allow home administration, but that also can result in high viscosity and/or higher doses which may not be appropriate for traditional autoinjector devices.”

This exclusive *Drug Development & Delivery* report highlights the innovation in injection devices – from wearables to connectivity to varied dose administration – that have occurred in the past year.

Mitsubishi Gas Chemical Company, Inc.: All the Benefits of Glass & Plastic Without the Drawback

Traditional glass and plastic materials for syringes and vials are filled with problems. Glass suffers from a range of issues – such as high-breakability and poor PH stability – while plastic has an insufficient oxygen barrier and UV barrier. This led to the creation of OXYCAPT™, Mitsubishi Gas Chemical Company’s new, light-weight, multilayer material.

OXYCAPT unites the best qualities of glass and plastic in a three-tiered, multi-layer, advanced material that features a water vapor layer made from COP (Cyclo Olefin Polymer) and a glass-like oxygen barrier layer with an oxygen-absorbing polymer. With low extractables, low pro-



The OXYCAPT™ Multilayer Plastic Vial & Syringe from Mitsubishi Gas Chemical Company, Inc.

tein absorption, and low breakability, all components come together to produce a high oxygen barrier material.

“We have received a lot of inquiries about ready-to-use plastic vials because more pharmaceutical companies have installed aseptic filling machinery,” says Tomohiro Suzuki, Associate General Manager, Mitsubishi Gas Chemical Company. “We have tried to reduce the total amount of silicone oil to prevent protein aggregation, and have made plastic vial and syringes with a high gas and ultraviolet barrier to solve the problems about breakage and delamination of glass.”

BD Medical - Pharmaceutical Systems: Responding to the Evolving Biologics Landscape

Biologic therapies that are in development now to treat chronic diseases are raising the bar for injection technologies. The high-dosage, high-volume, high-viscosity formulations in development can create usability challenges in terms of handling comfort and force exerted. Total system integration – where all parts in drug device combination products operate seamlessly together to deliver reliable performance – can be especially challenging with these

formulations. Further, patients’ and health-care providers’ level of sophistication and expectations for the injection experience are evolving. Fluidity characterizes this industry, and biopharmaceutical companies must adapt quickly to the changing environment.

“The availability and variety of device platform technologies is also expanding,” says Beth DiLauri, Global Marketing Director at BD. “It’s an exciting time for the in-



BD Intevia™ autoinjectors deliver high-volume, high-viscosity biologic therapies.

dustry and BD is integrating all these dynamically changing needs and requirements into our portfolio of high-volume, high-viscosity solutions for biologic therapies. We address emerging pharmaceutical needs with platforms that are in development such as BD Intevia™ autoinjectors, BD Libertas™ wearable injectors, and BD UltraSafe Plus™ passive needle guards.”

To achieve the flexibility desired by its customers, the BD Neopak™ prefillable syringe technology for biologics is integrated into BD’s delivery solutions to achieve high performance and enable choice of platforms to serve various end-user and therapeutic needs, says Ms. DiLauri.

BD is also actively investing in smart options that enable connectivity to address the changing needs of the healthcare ecosystem. For example, BD Libertas™ smart technology utilizes a modular approach through a customizable top case that incorporates sensors and electronics, providing pharmaceutical companies with an optional technology that can offer smart features, or not, depending on the needs of patient populations and therapies.

Credence MedSystems, Inc.: Overcoming the Challenges of Intravitreal Drug Delivery

With approximately 1.3 billion people worldwide victimized by some form of blindness due predominantly to macular degeneration, diabetic retinopathy, ocular vein occlusions, endophthalmitis, and retinitis,² and with the booming growth of the over-65 population from 630 million today to 1.2 billion in 2030, the pharmaceutical industry’s focus on therapies delivered via intravitreal injection continues.³ This is leading to a forecasted growth in the in-

The Credence Micro-Dose™ syringe is specifically designed to meet the needs of intravitreal injection procedures.

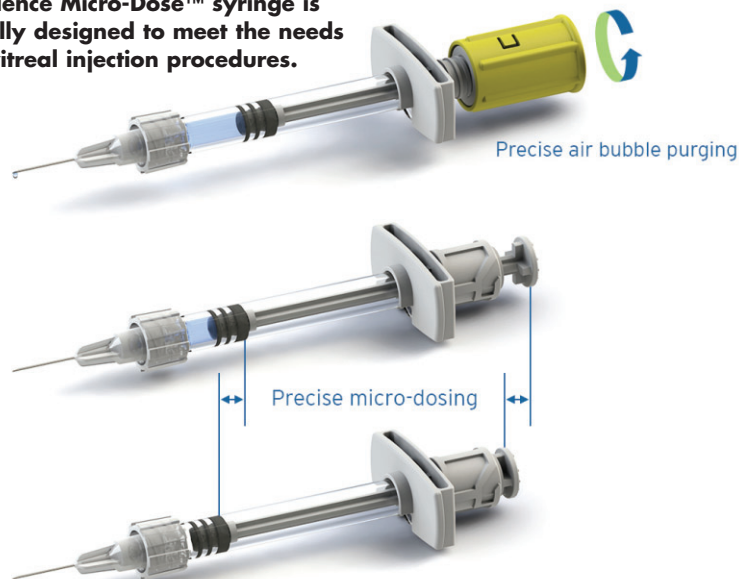

travitreal injectables market of 4.8% CAGR from 2018 to 2026.⁴

As with any therapy, delivery systems for intravitreal injections should seek to minimize safety risks, facilitate administration of the correct dose, and minimize disruption to pharma’s established processes, says John A. Merhige, Chief Commercial Officer, Credence MedSystems, Inc., which has developed the Micro-Dose™ Syringe System. Mr. Merhige says the design of Micro-Dose reduces the unwanted variability during use that can lead to patient risk. “Intravitreal injections have specific challenges related to the sensitivity of the injection site and the extremely low dose volumes, which are in the 50µL range for conventional indications and even lower for newer therapies,” he says.

For example, air injected into the eye causes significant pain for the patient. With Micro-Dose, the clinician purges the air bubble in a controlled manner by turning the safety cover until it automatically detaches, revealing the thumbpad. In addition to adding a greater level of certainty that the air will be purged, this process eliminates the drug spillage that can occur in conventional debubbling from overcoming

the plunger break-loose force. With such low volumes, any significant spillage will lead to underdosing, says Mr. Merhige.

“The conventional procedure is further susceptible to mis-dosing due to its inherent variability,” he says. “With the conventional injection process, the clinician is required to eyeball the correct dose by attempting to place the plunger adjacent to a dose line on the syringe,” he explains. “This variability leads to the risk of under or overdosing.”

With Micro-Dose, the clinician simply presses on the plunger rod until it stops moving. The permitted travel length of the plunger rod determines the dose ‘by design,’ enabling an extremely precise delivered dose. Additionally, Micro-Dose allows the clinician to achieve a comfortable grip, unfettered access to the injection site and efficient completion of the procedure.

The system is compatible with conventional needles or can incorporate Credence’s proprietary needle-retraction system. An additional option exists to include a feature that reduces the user force required for injection of viscous products. Mr. Merhige adds that Micro-Dose has been designed to allow implementation

without disrupting already validated primary package choices or manufacturing operations. The design incorporates few additional components and is compatible with any prefilled syringe. Secondary assembly on already-filled syringes is straightforward in implementation on existing processes.

Enable Injections: Wearable Infusor Platform for Larger Volume Drug Delivery

Biologic therapies often start with intravenous infusion and require large volumes for efficacy. Transition to subcutaneous delivery may require even higher volumes due to bioavailability. These large volumes are not suitable for administration via autoinjectors and prefilled syringes. Infusion pumps capable of delivering large volumes are available for subcutaneous delivery in the home, but they are complex, and often require in-home infusion services for administration.

“Enable Injections believes that patients will benefit, and pharmaceutical companies will be able to differentiate products, from a patient-preferred, on-body infusor platform,” says Jennifer King, Marketing Manager, Enable Injections. “Our goal is to move patients out of the clinic for drug administration, reducing the cost of healthcare and potentially improving patient quality of life.”

The enFuse®, developed and manufactured by Enable Injections, is an on-body infusor that has been designed with the patient in mind. The enFuse technology has an elastomeric balloon that acts as the storage reservoir of the therapeutic as well as the power source for the infusion. The size of the infusor is minimal and allows a larger wearable volume for the patient, says Ms. King. The enFuse utilizes standard container closure systems for point-of-care filling.

The enFuse is being developed to accommodate subcutaneous infusion volumes of up to 50ml of biopharmaceutical or pharmaceutical therapeutics. The enFuse contains no electronics, and infuses via constant pressure from the elastomeric balloon.

The next-generation enFuse will incorporate Bluetooth technology to provide a tool for patients to plan for, and track, infusions on their smartphone. “The technology design is planned to include remote patient monitoring, which may have the potential to improve treatment adherence,” she says.

PUTTING PRACTICE INTO BEST PRACTICES



Noble's training solutions improve patients' injection technique and set your brand up for success.

GoNoble.com

The enFuse® on-body infusor from Enable Injections delivers up to 50ml of therapeutics.



SHL: Scalable Device Manufacturing for Variety of Production Volumes

The development of biologics and biosimilars has opened up avenues for personalized medicine: treatments targeted for niche disease cohorts with higher precision for enhanced treatment outcomes. With some of the first tumor necrosis factor (TNF) alfa inhibitors going off patent, the autoinjector market is expected to grow in overall size but diversified into several drug products. This means that device providers are now being challenged to produce autoinjectors in a variety of manufacturing volumes – ranging from several hundred thousand to several million devices per year for a single project – in different levels of customized or bespoke industrial designs.

Because most autoinjectors are designed for low- to medium-volume production, this paradigm shift calls for flexibility. Owning the full range of development and manufacturing capabilities in-house, SHL meets the challenge for scalable production through a modular approach to both the design of the autoinjector as well as the design of the assembly and testing machinery.

SHL has adopted a modular, multi-device strategy for its automated equipment. This approach makes it possible for components such as fixtures and grippers to be

interchanged so that a variety of devices, or several different versions of the same device, can be operated on the same machinery. “Modularized automation not only enables scalable production, but it also improves quality, consistency, and accuracy because it decreases variation caused by

human handling and facilitates a repeatable process that can be utilized in several production lines,” says Magnus Fastmarken, Director of Marketing, SHL. “By interchanging several components on one singular equipment, or strategically mixing and matching different module types, SHL ensures the reusability of a modular system for the vast and often varied forecasts for clinical or commercial needs.”

The evolution of the Molly® autoinjector is an example of how SHL is meeting the trend for scalable device manufacturing through its designs. Molly is a preconfigured autoinjector created to reduce costs and shorten development timelines. Molly is known for its easy-to-use, 2-step operation and compact design. And its production has been supported by SHL’s manual and semi-automated capabilities to fulfill



SHL's modular approach to automated assembly and testing equipment facilitates increased production flexibility and high-quality deliveries.

low- and medium-volume requests.

Now, a second-generation has been developed with a new ergonomic design and a flange-shaped anti-roll cap for an easier handling experience. "For SHL, manufacturability is as important as functionality, which is why the design has also been optimized for automated production," says Mr. Fastmarken. "This includes additional flexibility in sub-assembly and final assembly options, as well as an expanded scope for syringe choices."

The first autoinjector based on the new Molly technology for high-volume production is already in development and is due for commercialization in 2020. To ensure the autoinjector design is seamlessly integrated with its production equipment, SHL's cross-functional teams of industrial designers, assembly system engineers, tooling engineers, and molding operations collaborate closely. Fastmarken says: "This truly integrated approach to development and manufacturing makes it possible for us to scale volumes according to customer requirements, and develop completely bespoke devices based on customer needs."

Nemera: Focused on Larger Volume Injectable Devices

Biologic drugs are often needed in high concentration: this can be driven by the nature of the molecule, composition of the final drug, and by the effort to decrease the frequency of treatment for the patient. Their viscosity increases as a power law of the antibody concentration. To be injected, these molecules need to be diluted, which leads to higher injection volumes, and lower (but still high) viscosity. As a result, volume is shifting towards 2ml.

Nemera's focus has been on larger volume injectable devices; Nemera's par-



enteral devices are specific to injecting large volumes such as 2ml and larger. The Safelia® autoinjector device can inject up to 2.25ml fill volume, with high viscosity. And in the past year, Nemera commercialized the Safe'n'Sound® add-on safety 2.25ml device. The single-use device helps prevent needlestick injuries and is compatible with prefilled syringes. And the Safe'n'Sound 2.25ml platform is suitable for low-fill volumes and higher viscosity formulations.

"Our 2.25ml size is specifically relevant to administer complex, high-value drugs such as monoclonal antibodies or other biological therapies," says Severine Duband, Global Category Manager for Parenteral at Nemera.

Additionally, Nemera has been working to bring connectivity to devices, either as an add-on or in an integrated device. Its on-body injector platform, which is in development, incorporates this technology into a smart wearable platform. The platform in development is composed of a reusable and rechargeable part as well as a disposable part containing the drug, needle, and sticker patch.

Ms. Duband says key benefits include an adjustable flow rate, automatic needle insertion, and smartphone communication including treatment information, reminders, and compliance features.

"As a platform, is it highly customizable and flexible, and can adapt to any type of therapeutics requiring the injection of large volumes," she says

Noble: Training to Prevent the "Forgetting Curve"

The continued growth of self-injection therapies will lower dosing frequencies. While this improves the patient treatment experience by reducing the burden of self-injection, it also increases the risk that patients will forget the proper self-injection process due to training decay, says Joe Reynolds, Research Manager, Noble.

Noble's patient training solutions are specifically designed to assist patients with overcoming the impact of the "forgetting curve" by allowing them to practice with a resettable training device that closely replicates the drug delivery process.

Noble has focused primarily on the development and manufacturing of platform demonstration training devices based on the BD UltraSafe™, BD Physioject™, and Ypsomed YpsoMate® injection devices. "Following the lead of these drug delivery device manufacturers, Noble has invested in platform demonstration devices that allow our pharmaceutical customers to bring trainers to market with greater speed and lower tooling investment," says Mr. Reynolds. "Our focus is not only to design, engineer, and produce the highest quality training devices to improve patient adherence, but also to build a device launch strategy for commercial teams that ensures both a successful start and recurring long-

WE HAVE THE TOOLS FOR TRAINING SUCCESS



noble[®]

Find out how Noble's training technologies can help improve patients' injection technique and set your brand apart from the competition.

Request a sample today at
GoNoble.com/Solutions
or scan code



© 2019 Noble International, Inc.
All rights reserved. Patents pending.

Noble's training solution help patients remember how to self inject.



term success."

Noble is currently developing a training device to support the launch of the BD Libertas™ wearable device. Mr. Reynolds says: "As the demand for this wearable device grows, pharmaceutical customers who use Libertas to deliver higher drug doses will have the opportunity to deploy our Libertas demonstration device to ensure patients fully understand how to use these novel drug delivery devices."

DDL, Inc.: Lab Addresses Dynamic & Analytical Testing

A common approach for drug development includes the use of ICH stability conditions to subject the product to varying environmental conditions. Subsequent stability pulls are tested against a battery of tests to ensure the safety, purity, and potency of the drug product. Take the case of an injectable biologic product. Depending on the firm's risk appetite and the regulatory pathway, the initial GMP batches are filled in a vial or prefilled syringe, packaged, and carefully carted to the stability chambers for their iterative cadence of stability, followed by analytical testing. Acceptable stability profiles against the various product tests keep the program alive.

Fast forward to design verification, where the device portion of the combination product is put through the ringer. A common approach includes a bombardment of physical stressors on the final-finished package configuration, which simulates a variety of transit conditions one would expect for the mode of distribution chosen for the given product. The resultant units are commonly placed into ICH stability conditions where an iterative cadence of stability is followed by physical testing to ensure the functionality of the device. Such tests include mechanical testing, particulate analysis, and container closure integrity.

DDL collaborates with companies developing injection devices by providing performance and mechanical testing, long-term stability studies, and packaging validation.



But this creates a gap. The early-stage GMP batches put on stability are typically never subjected to physical stressors, from a dynamic perspective. During design verification, the product is subjected to physical stressors, from a dynamic perspective, but is not scrutinized from an analytical perspective. Furthermore, recurring stability studies during commercial production will likely not account for the stress put on the product during transit and distribution.

Injectable biologic products are some of the most sensitive therapies in development and on the market. Using the example of proteins, the efficacy of these highly complex molecules can sometimes depend on low-energy interactions such as hydrogen bonding and van der Waals forces. Subjectation of these molecules to the harsh conditions of transit and distribution can alter their conformations, cause precipitation or aggregation, or accelerate degradation. By not testing the product against the analytical battery of tests after transit and distribution simulation, application holders run the risk of an adverse event occurring.

"R&D scientists and engineers should consider the dynamic component when executing stability studies, no matter the

stage of development," says Joseph Wojcik, Program Manager, DDL, Inc. "Additionally, biosimilar application holders should closely examine innovator package configurations when reverse engineering those products. Subtle choices of syringe placement, tray design, and carton design can impart differing forces onto the drug product within the device. Lastly, as biologic products evolve into pen-injectors for home administration, application holders ought to consider the conditions likely to occur between the pharmacy and the patient's home refrigerator or freezer."

Sonceboz: Mechatronics Enable Easy-to-Use Injection Devices

Sonceboz is developing a technology platform designed around a pump module that uses vacuum to gently withdraw liquid drugs from their respective containers before delivery into the subcutaneous space. This enables a high degree of compatibility to primary drug containers of different forms and capacities without the need to change the overall system architecture. The pump comes with multiple channels to

allow for complex therapeutic applications, such as drug combination therapies or drug mixing and reconstitution, all within the embodiment of the device.

"The advantage of our approach is reliance on one proven system and thereby accelerated development and time to market," says Thomas Mayer, Business Development Manager, Sonceboz. "These characteristics are important to providing a drug delivery platform that works from clinical trials to lifecycle management."

The Sonceboz platform has built-in connectivity using Bluetooth Low Energy as the communications standard. "Because our drug delivery systems are electro-mechanical and equipped with smart sensors, we can provide a variety of data for transmission using connectivity," says Mr. Mayer. "Depending on the needs of our pharma partners, we transmit information, such as time and volume of delivered dose."

Sonceboz is also designing a platform of wearable injection devices: LVI™, DCI™, and ARI™. The LVI family comes in two different forms: cartridge based and either user loaded whereby the patient inserts a filled cartridge into the device prior to use or prefilled and preloaded with the drug container already installed in the device. The LVI-V™ can handle drug payloads up to 20ml and comes with a vial-adaptor that allows for the automatic transfer of liquid drugs into the device. In that case, a temporary drug container is used inside the device for short-term storage. This device is intended for use during clinical trials.

The DCI device uses two cartridge containers simultaneously. This allows for combination therapies in oncology or when one wants to keep the existing drug container but double the delivered payload. The ARI is intended for automatic reconstitution of



The Sonceboz wearables injection device platform.

lyophilized drug products. A prefilled and loaded diluent reservoir is inside the device and reconstitute is in a connected vial, which is removed prior to attachment on the patient's skin. "This simplifies the use of lyophilized products and supports self-administration," says Mr. Mayer.

Sensile Medical: Wearable Pump Targets Parkinson's Disease

A delivery device is defined by the drug to be administered, the treatment regimen, and the patient. Opinions of patient groups, healthcare providers, the patient's physical condition, and the place of administration are all taken into account during early handling studies to address all stakeholder needs. No matter which patient group receives the device, Sensile Medical's devices are tailored and customized for the individual patient group.

For example, the first micropump from Gerresheimer subsidiary Sensile Medical is now available on the market. Developed by Sensile Medical especially for EVER Pharma

under the brand name D-mine® Pump, this wearable infusion device with a micropump recently received European CE certification and has already launched in several European countries. "The compact, patient-friendly pump is used for the continuous subcutaneous administration of the drug to



This 20ml infusion pump for Parkinson's patients was developed by Sensile Medical and launched by EVER Pharma.

treat the advanced state of Parkinson's disease, and may give patients more autonomy in their daily lives," says Sandra de Haan, Chief Business Officer, Sensile Medical. "Considering the impairments caused by the disease, it was crucial to develop a device that is safe and easy to handle for those having difficulties coordinating their movements."

Sensile also addresses the demand for technologies for eHealth applications and is working on connectivity solutions and sensor technologies as an option for device flexibility and modularity. "As our technology is driven and controlled by electronics, connectivity is straightforward to implement," says Ms. De Haan. "These electronically controlled devices offer a variety of options for dosing that are pre-set or adjusted by healthcare providers or patients."

West Pharmaceutical Services, Inc.: Wearable Platform, Injection Technology Empower Patients

In the biologics space, there is a clear trend toward higher delivery volumes, less frequent dosing, and the conversion from intravenous to subcutaneous delivery. This is driving demand for wearable technologies. West's wearable solution is the SmartDose® drug delivery platform. West has commercialized the SmartDose Gen I 3.5ml device, and will soon bring a higher volume SmartDose device to market, supporting delivery up to 10ml.

SmartDose Gen I 3.5mL is a device with Amgen's Repatha, where it provides a single, monthly dose delivery option. Gen II incorporates technical and human factor improvements and supports up to 10ml delivery. "Our SmartDose devices can address multiple disease states from oncology and autoimmune to CNS, and

Differentiate your drug delivery



Connected, Needle-free Drug Delivery

Available today for your feasibility Studies & Testing



Portal Instruments

West's SmartDose® wearable drug delivery platform provides a range of wearable dose and delivery options, while the SelfDose™ patient-controlled injection technology offers lower volume delivery.



empower patients to treat themselves in the comfort of a clinic or their own home vs. a hospital setting, with fewer injections than a multiple autoinjector alternative,” says Aileen Ruff, Senior Director, Strategic Marketing, Biologics, West Pharmaceutical Services, Inc.

scPharmaceuticals Inc. announced its intent to go to market with West’s 10mL SmartDose® device for FUROSCIX®, a proprietary furosemide solution for treatment of edema in patients with congestive heart failure. FUROSCIX is formulated for subcutaneous delivery, and West’s SmartDose wearable drug delivery technology provides an outpatient alternative for the treatment. Alexion has also announced its adoption of SmartDose for two blood disorder products. ALXN1210 utilizes the Gen I 3.5mL SmartDose device to help eliminate up to two hospital visits per week for patients.

“To further strengthen the offering to our customers, early in 2019, West and Swissfillon announced a partnership for an integrated solution for clinical filling of

SmartDose Drug Delivery Platform Cartridges,” says Ms. Ruff. “Taking away possible challenges in the supply chain around upscale of fill-and-finish activities contributes to a smoother journey to approval for our pharma clients.”

West also partnered with Accord Healthcare Limited to develop a delivery device for a weekly single-dose injection of its drug Methofill™ (methotrexate) SELF INJECT. The incorporation of West’s SelfDose™ technology supports the required dosing level and ergonomic design, which allows Rheumatoid Arthritis patients with dexterity issues to self inject outside of a healthcare setting. West’s SelfDose patient-controlled injection technology is for volumes lower than 3.5mL.

Haselmeier, Inc.: Injection Pen Administers Single-Fixed & Multiple-Select Doses

The continued growth of new biologic therapies, biosimilars, and other novel drugs combined with a shift towards

self administration of these therapies outside of a clinical setting, mostly at home, is creating an increased focus on the design, effective use, and safety of the drug delivery system. Haselmeier, Inc. views these trends as an opportunity to apply patient-focused design and development processes to the next generation of injection systems. The most recent result of this patient-centered development process is the D-Flex Injection pen.

D-Flex is a manual injection pen platform for the administration of a small number of selected doses. In some therapies, treatment specifies a finely adjusted variable dose. “Typically, a variable dose injection pen will be used for that kind of application, however, those injection devices have a myriad of injection volumes for the patient or healthcare practitioner to accurately use,” says Terence O’Hagan, General Manager, Haselmeier, Inc. “Too many choices represent a significant potential use error in applying the wrong dose.”

Other therapies may require just one fixed dose and a fixed-dose injection pen is used. Mr. O’Hagan says these pens are limiting in use. “The D-Flex manual injector pen platform brings the worlds of fixed-dose and limited-variable dose pens together with a device that makes it easy to select one fixed or several fixed doses on the same device, and includes a mechanism that prevents the selection of unintended doses.”

Haselmeier, in cooperation with Common Sensing, announced a connected D-Flex injection pen that can be paired via Bluetooth with a smartphone. Called D-Flex Connect, the reusable pen cap replaces the standard cap, so the patient has the advantage of

Aptar Pharma Injectables QuickStart™ is a sterile, Ready-To-Use, comprehensive drug development support solution.



already being familiar with the use of the device, says Mr. O'Hagan. In addition to providing the date and time of an injection, D-Flex Connect provides the actual dose volume delivered by the patient while also advising on remaining volume in the cartridge. "This information provides a clear picture of the patient's treatment status, while having the capability to communicate this information to selected stakeholders about their treatment including family members, caregivers, and physicians," he says.

Aptar Pharma: Setting a Standard of Cleanliness in Elastomeric Components

From increased regulatory requirements to internal development of extremely sensitive drug formulations, Aptar Pharma's clients look to the drug delivery provider to support these needs. This is most evident in the company's quality control process offering, PremiumVision™. This in-line, automated vision inspection system validates against critical defects in elastomeric components. "We are actively setting new standards for particulate reduction and molding consistency with

PremiumVision," says Adam Shain, Director, Global Business Development, Aptar Pharma, Injectables. "We have invested heavily in PremiumVision across all three of our manufacturing sites – two in France and one in the U.S. – because it is critically important in the delivery of more sensitive and expensive drugs, including complex proteins."

Aptar Pharma is also focused on helping its customers get to market quickly. To support this, the company developed Aptar Pharma Injectables QuickStart™, a sterile, Ready-To-Use, comprehensive drug development support solution designed specifically for universities, start-ups, and customers' R&D labs. "The components satisfy all regulatory requirements, delivering commercial-scale quality at a development stage cost and reducing bench-to-market time," says Mr. Shain.

With regard to its own portfolio, Aptar Pharma has connected devices and is actively looking for opportunities related to wearable technology. "Connected medicines hold great promise for improving medication adherence, reducing health-care costs, and, ultimately, improving patient outcomes," he says. And, while we do not currently offer an off-the-shelf wear-

able solution, our elastomeric components are utilized by wearables manufacturers."

Consort Medical – Bespak Drug Delivery Devices: Faster Delivery of Viscous Drugs

Consort Medical – Bespak Drug Delivery Devices has developed a range of delivery devices specifically targeting high viscosity drugs and higher delivery volumes. "Consort believes these are a game changer for the industry, which has not previously considered this to be an option, and have instead aimed for lower viscosities in their formulation work or selected more complicated and expensive body-worn delivery devices to deliver higher volumes," says Hans Jensen, Global Business Development Director, Consort Medical – Bespak Drug Delivery Devices.

Viscous drug delivery with minimized

The Syrina AS is a platform autoinjector, powered by VapourSoft technology that uses liquified gas to drive the delivery of highly viscous formulations, while minimizing patient discomfort (Consort Medical – Bespak Drug Delivery Devices).



needle insertion pain is enabled with Consort's VapourSoft technology, which uses liquified gas instead of conventional springs in delivery devices such as the Syrina AS autoinjector. Syrina AS targets a range of biological drugs, such as monoclonal antibodies as well as depot or long-acting formulations of small-molecule drugs. Mr. Jensen says: "The device is designed in a way that makes it easy to modify to meet specific customer requirements."

Initially developed to deliver 2ml of a 50cP viscous drug product in less than 10 seconds for a specific version of a PFS, customizations to the device can be made in just a few weeks to deliver fully functional devices based on a client's specifications for ISO 11040-compatible 1ml- or 2.25ml-prefilled syringe (glass or plastic), drug viscosity, fill volume, needle size, and delivery time, he says.

DALI Medical Devices: Connectivity Keeps All Interested Parties in the Loop

While the global homecare market promotes convenience while reducing medical care costs, the trend is taking its toll as home-medicating patients need to be closely monitored for their adherence to treatment. This need becomes even greater for companies conducting a clinical trial that involves a large number of patients, scattered over remote locations, resulting in a complex study follow-up.

DALI is currently developing the Synnect™ platform to address these monitoring needs. Synnect will be an add-on device fitted to standard and safety syringes or to DALI's SAN™ (Safe Auto-Needle) products, as well as to autoinjectors. This platform transmits real-time injection data to a ded-

icated smartphone app that uploads the data to a secured cloud. Unlike other connectivity injection devices, Synnect senses the injected volume not just injection completion, says David Daily, MSc, MBA, CEO & Co-founder, DALI Medical Devices Ltd.

"An effective clinical study monitoring could significantly reduce the clinical studies drop rate (currently ~30%), as fewer patients would be excluded from the study," says Mr. Daily. "On top of that, home treatment would ease patient recruitment, as it spares the hassle of clinic appointments."

In addition to the Synnect platform, DALI is introducing the SAN product family. These products combine automatic needle insertion, similar to automatic injectors, as well as manual control over injection speed, similar to standard syringes, he says.

The current focus of DALI's team has been the SAN-L, which is under final development stages. SAN-L is an automatic needle designed to fit all luer-lock syringes. Features include truly hidden needle, automatic needle insertion for accurate needle penetration, and passive safety sharps protection.

Another member of the SAN family, the SAN-Light safety needle was selected by a European pharma company for help with an injection device for its biological drug, which is highly viscous and challenging for intramuscular injection. To solve this problem, the DALI SAN-Light safety needle has been carefully customized: a larger needle has been selected to enable continuous drug flow, and the device fitting has been redesigned to connect to a unique sy-

The DALI Synnect™ Connectivity platform for syringes, safety syringes, SAN™s and autoinjectors.

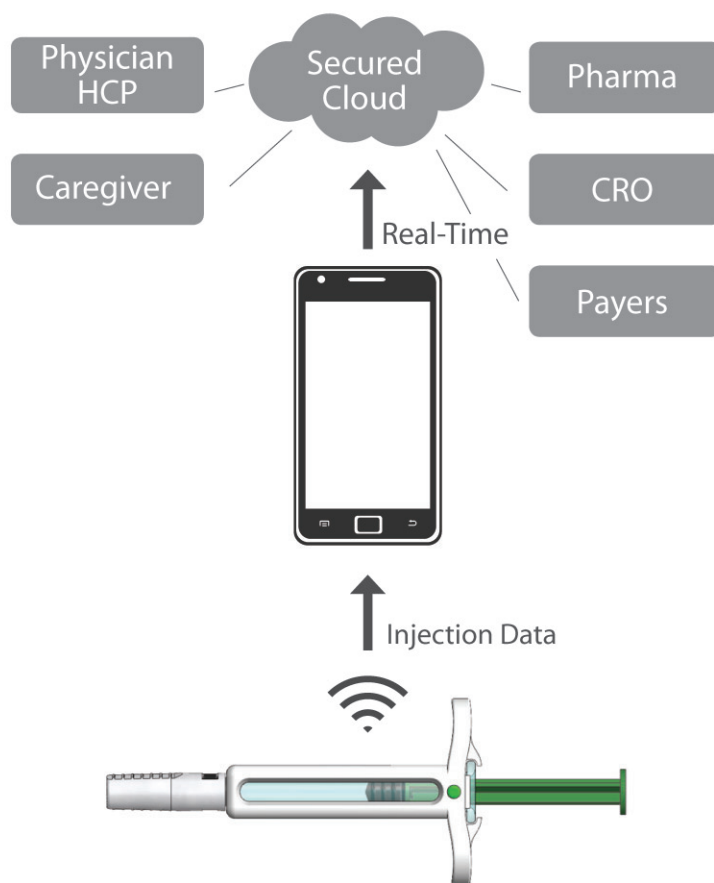

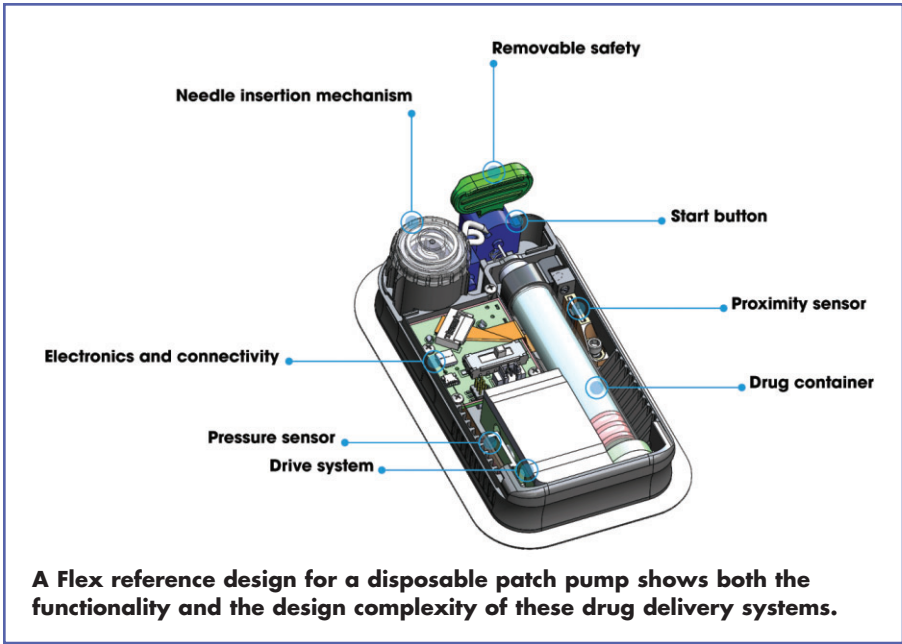

and contact; and minimizing form factor for connectivity module and drive systems.”

**Kahle Automation:
Micro-Assemblies & Components
for Wearable Injection Devices**

As products are getting smaller and tolerances are getting tighter, this puts pressure on the automation suppliers and component suppliers to produce high-volume components at much tighter tolerances. These micro-assemblies and associated micro-components are crucial to the functionality of today’s complex drug delivery and diagnostic devices, states Julie Logothetis, President of Kahle Automation.

Kahle designs and builds automation equipment for micro-assemblies with production outputs ranging from 10ppm to 630ppm. Its knowledge includes the feeding and assembly of molded components, tubing, and cannula as small as 6mm long and 32G. Its equipment can integrate

ringe. The customized SAN-Light has passed its verification and validation, and is expected to be launched to the EU market in 2020.

Flex Health Solutions: Designing & Manufacturing Connectivity & Wearability into Injectors

Freedom from user error is paramount and Flex Health Solutions incorporates specialized expertise in needs analysis and human factors in the design process. Flex’s design and manufacturing involvement in various industries has allowed the company to transfer its knowledge in connectivity to healthcare, explains Patty Kamysz, Marketing Manager, Flex Health Solutions.

One critical area is low-cost modules for single-use disposable devices, where such technology was previously cost prohibitive, she says. Flex partners with pharma companies to help them choose the right kind of connectivity and to advance them to the next step in drug delivery, providing patient compliance monitoring and enriched drug delivery through feedback and analytics. Flex has been focused on various injection devices including pen injectors,

autoinjectors, wearable injectors, and disposable and reusable devices. The therapeutic applications Flex is targeting are diabetes, cancer, arthritis, and other autoimmune diseases.

“Flex has a solid track record in designing and manufacturing complex electro-mechanical autoinjectors – especially the current market where pharma is aggressively targeting biologic solutions that make simple autoinjectors impractical due to the high viscosity and large volume,” says Ms. Kamysz. “We simplified the device interactions by using electrical motors rather than relying on the patient’s ability to inject. Patients are now equipped with tools that guide them through injection via dynamic user interfaces.”

Ms. Kamysz says Flex recognizes the importance of wearables as a new category for drug delivery devices. “We developed a platform device that allowed us to tackle some of the most complex challenges: how to integrate a prefilled industry standard primary container to eliminate patient filling; creating low-cost solutions in connectivity for compliance monitoring that integrates into a full health cloud solution; sensor integration to indicate positioning



micro-dispensing, vision and leak testing, punching filters and diagnostic mediums, welding, and cannula bending.

Kahle recently completed several projects involving the assembly of the internal fluid path of wearable injection devices. "It is critical for these products to keep the fluid path patent even through the complex maze of tubing and bent cannula required to navigate the path within the internal working of the device," says Ms. Logothetis. Kahle offers cannula bending technology that can bend 29G cannula up to 120 degrees while maintaining orientation of the ground sharp.

In addition, Kahle has provided the automation for the manufacture of an ocular injection device that will allow the practitioner to perform a precision injection in the eye to the exact point of treatment, she says.

Duoject: Improving User Safety & Compliance Through Product Design

During this past year, Duoject has been seeking ways to increase safety for prefilled syringe users. This involved reviewing all commercially available safety engineered syringes to better understand how they are used and how they currently address user safety, explains Dan MacDonald, Vice President – Engineering, Duoject.

"We realized that most existing technologies on the market have some drawbacks, such as exposed needles prior to injection, risks of cross contamination or requiring changes to the primary container in order to integrate the safety solution," he says. "We set out to develop a new safety syringe technology addressing these issues. The device is designed to prevent sharps exposure potentially leading to end-user injuries, all the while optimizing the assembly

Duoject's new safety device is compatible with standard prefilled syringes and provides protection throughout the sequence of operation.



process with standard unaltered PFS."

Duoject is also working to enhance its portfolio in the areas of reconstitution and administration devices. Duoject has improved existing technologies and developed new devices, such as vial-to-cartridge, vial-to-syringe, and vial-to-vial reconstitution platforms. Duoject has also developed new cartridge- and PFS-based injection solutions. "These new developments were designed for homecare users and healthcare professionals, providing safe and intuitive single-use solutions to the end-user," says Mr. MacDonald.

In addition to focusing on end-user safety, Duoject is also exploring opportunities in the area of connected devices aimed at improving treatment compliance. To that end, Duoject has developed and patented a mechanical injection detection system that, when triggered, sends a signal to a user's smart device. Mr. MacDonald

says the company plans to continue exploring this field, both in-house and through partnerships.

SiO₂: Closing the Gap on Zero Particles in Prefilled Syringes

Particles are omnipresent in the manufacture, storage, and delivery of biologic drug formulations. There is universal agreement that particles provide no therapeutic benefit, and in many cases are detrimental to the efficacy and quality of biologic drugs. Worst case, adverse drug reactions, including death, may result in patients injected with particle-ridden biologics.

Product recalls associated with particles is an ongoing problem that has the attention of regulatory authorities. While the pursuit of "zero particles" may never be achieved, there is plenty of room for improvement. United States Pharmacopeia

Real World Challenges in Drug Delivery and Formulation



The Objective

A preclinical stage novel biologic needs to be formulated for optimal subcutaneous injection for upcoming proof-of-concept Phase I trial.

The Challenge

How do I quickly identify pH limits, excipients and administration volume for currently approved subcutaneously injected biologics?

The PharmaCircle Solution

- 1 PharmaCircle's intuitive interface allows for rapid data extraction and analysis.
- 2 pH range and administration volume are provided as clickable charts with supporting data tables which you can modify and export as a spreadsheet.
- 3 Similarly displayed excipient detail includes quantitative excipient amounts correlated to each product and strength.



**Get your search results in less than
a minute with PharmaCircle**

To learn more about this search capability and other PharmaCircle solutions, contact us at:

1-800-439-5130 or visit

www.pharmacircle.com



SiO₂ ophthalmic ready-to-fill luer syringe (0.5ml) with OVS safety cap.

(USP) guidelines govern the acceptable visible and subvisible particle loads in pharmaceutical injections. The most recent quality guidance for ophthalmic drug products, USP <771>, sets the most stringent subvisible particle load limits for intravitreal injections according to USP <789>. All other extraocular injectables are subjected to limits that some argue to be too lenient (USP <788>).

“Primary packaging innovation is essential to closing the zero-particle gap, particularly subvisible particles,” says Christopher Weikart, Chief Scientist, SiO₂ Medical Products (SMP).

SiO₂ Medical Products took a leap toward zero particles with a hybrid ophthalmic 0.5ml prefilled syringe, says Dr. Weikart. The SMP syringe barrel is composed of a medical-grade cyclic olefin polymer (COP), internally coated with a silica-based barrier and lubricant coating system. The lubricant coating, a

crosslinked organosilica, was engineered with lower subvisible particle loads than ordinary silicone oil lubricants without sacrificing plunger force performance or container closure integrity (CCI), says Dr. Weikart. “Key benefits include the use of standard plungers with sustainable CCI over the product shelf life and particle loads up to 80% lower than USP <789> guidelines.”

The problem with too many lubricant particles in biologic drug formulations is aggregates. Some biologics (e.g. proteins) interact with lubricant droplets causing them to stick together. Bound proteins are unavailable for therapeutic action once injected into the bloodstream. Surface interactions with the syringe barrel can also generate aggregates. Proteins bind to the surface forming regions of protein stacking that can slough off into solution due to shipping, storage or delivery stress.

“Generally, fewer lubricant droplets means fewer aggregates, which has been observed with polyclonal antibody formulations stored in SMP syringes subjected to various stress,” says Dr. Weikart. “The hydrophobic chemistry of SMP coatings are engineered to minimize protein binding, which reduces the chance of aggregates.”

Just as microbial invaders trigger immune response and adverse drug reactions, aggregates can have the same effect. The triggering system, called complement activation, involves proteins signaling killer cells to the battle. “Accelerated freeze-thaw and agitation stress on polyclonal antibody (pAb) formulations stored in SMP syringes exhibited significantly fewer aggregates compared to ordinary glass syringes with silicone oil lubricant,” says Dr. Weikart. “Complement proteins measured in pooled human serum combined with stressed pAb formulation was correspondingly lower stored in SMP

syringes compared to glass.” He adds that this dependence was only observed for particles less than 10µm in size, which are not currently regulated by USP guidelines.

Ypsomed: Focusing on Large-Volume Injections, Cloud-Connected Devices, & Services

Following the recent launch of the YpsoMate 1ml device and impending first launch of YpsoMate 2.25ml, Ypsomed is focused on developing the large-volume 3-10ml YpsoDose prefilled patch injector. A recent handling study with the 10ml YpsoDose confirmed its suitability for use by patients and healthcare providers, says Ian Thompson, Vice President Business Development, Ypsomed. “We have fully functional YpsoDose prototypes that pharma customers are putting through feasibility studies,” he says.

The main benefit of the YpsoDose patch injector is to allow users to perform infrequent injections in an efficient and convenient way, saving significant costs for the healthcare system, states Mr. Thompson. The electromechanical, cartridge-based, connected device is based on a versatile platform customized into product specific variants to provide a reproducible injection for each drug. YpsoDose automatically inserts the injection needle at the start and retracts the needle at the end of the injection process.

“Big Pharma is looking for prefilled cartridge-based systems that are pre-assembled with the device and ready-to-use,” he says.

Connectivity will become instrumental in effective self management of chronic diseases. For instance, the reusable add-on SmartPilot for YpsoMate with built-in sensor technology and wireless communication capabilities transforms the 2-step autoinject-

Ypsomed's ready-to-use YpsoDose patch injector delivers 3-10ml (left) and the SmartPilot add-on transforms the YpsoMate autoinjector into a fully connected device (right).



tor YpsoMate into a fully connected digital health system. SmartPilot monitors device use and provides therapy-relevant injection data to providers, caregivers, and health-care stakeholders as well as patients through the self-injection process.

Implementing cloud-connected devices, however, does present some hidden challenges beyond the device. Thus, Ypsomed has entered a strategic collaboration with Royal Philips, a health technology provider, to deploy a new set of managed digital services – YDS SmartServices – that are enabled by Philips' HealthSuite digital platform, a cloud-based platform purpose-built for the complex challenges in healthcare.

"The connected device management solution securely and seamlessly provides relevant injection data to therapy solution providers, CROs, and other third parties," says Mr. Thompson. "We have built a full device management solution that allows our partnering pharmaceutical firms to rapidly develop therapy solutions that address non-adherence in clinical trials and post-market introduction. In short, Ypsomed ad-

dresses the device-oriented challenges so that our pharmaceutical partners can focus on the therapy-oriented challenges."

SCHOTT: Development Process Makes Devices More Comfortable for Patients

Typically, the drug delivery device is built around standard primary packaging containers, and that has constrained the

designers' ability to make the devices smaller and more comfortable in response to patient demand, says Tom Van Ginneken, Global Product Manager Polymer Platform, SCHOTT. "We have the capability to work with partners, such as device manufacturers, to co-create customized polymer containers," he says. "This means the container offers a perfect fit with the device without compromising device design."

The joint development process is based on a four-stage sampling process. Each stage of the sampling process provides individualized containers for different purposes in the drug development stage: from quickly delivered containers for design freeze of the concept to containers out of a semi-automated production line for a faster drug registration process. In addition, existing Drug Master Files (DMF) with polymer and different rubber formulations are available, leading to faster and easier regulatory filing, explains Mr. Van Ginneken.

"We have vast expertise in the area of primary packaging for injectables that



SCHOTT leverages its long-standing know-how and experience in manufacturing polymer pharma packaging to co-develop containers with partners that meet the needs of the drug product, filling process, and drug administration.

are used with injection devices,” he says. “The above-mentioned joint development process isn’t tied to one type of device or therapeutic area and is appropriate for any device and drug combination.”

Stevanato Group: Design & Development of Complex Delivery Devices

Biopharma companies are actively looking for suppliers that can design, develop, and manufacture complex drug delivery devices such as autoinjectors, pen injectors, and wearable injection systems. Typical device projects involve several companies who rely heavily on each other throughout development, testing, scale up, and commercial production. Sourcing from a single large partner may help ensure control of timelines and quality.

Stevanato Group offers a range of capabilities that are suited to device projects, either offering a contract manufacturing service or providing licensed and proprietary devices. Stevanato Group develops proprietary technology related to its 1ml wearable cartridge-based wearable, as well as customized primary containers, and in some cases, sterile fluid path support for a range of other wearables including ready-to-fill cartridges ranging in size from 1ml to 20ml.

The cartridge-based wearable device currently under development is composed of a disposable, wearable pod and an intelligent, reusable, handheld controller that serves as the user interface and control unit for the pod. The handheld controller uses magnetic coupling to manage the interaction with the pod, and, thanks to Bluetooth connectivity, allows injection data to be exchanged. “The device is suited to diabetic patients who wish to receive their insulin in



Stevanato Group provides equipment solutions for a range of device assembly.

a discreet manner without having to always rely on a pen injector throughout the day,” says Steven Kaufman, Vice President of Drug Delivery Systems, Stevanato Group.

In the area of contract manufacturing, Stevanato Group is working towards securing projects such as pen injectors, autoinjectors, and wearables where the design and the development of the device comes from biopharma companies. These programs are supported by Stevanato Group’s glass primary packaging facilities worldwide, plastic injection molding facilities in Germany and the US, and with sub-assembly, final assembly, and packaging equipment from its company in Denmark.

The Stevanato Group has developed the single-use EZ-fill® ISS, an Integrated Safety System for syringes that is delivered sterilized and ready for filling, allowing pharmaceutical companies to have an integrated needlestick protection to the syringe. The Integrated Safety System is composed of a rubber needle shield inserted into a plastic shield with flexible wings, combined with a ring and a hub, all pre-assembled on the ISS EZ-fill syringe.

EZ-fill ISS has been selected by a

CDMO, which estimates to reduce its Total Cost of Ownership up to 36%, says Mr. Kaufman. “EZ-fill® ISS allows less manufacturing and assembly steps as the safety device is already attached to the syringe,” he says. “Thanks to one single component and to the consequent slimness of packaging, each pallet unit contains 50% more single packs, allowing to save half of transport costs.”

Additionally, Mr. Kaufman explains that the Nest & Tub configuration in which EZ-fill® ISS comes, makes processing on existing fill-and-finish lines easy. “Small adaptations in packaging and format parts might be required, helping to reduce lead times,” he says.

References

1. Self-injection Device Market (Product Type - Pen Injectors, Autoinjectors, Wearable Injectors; Usage - Disposable, Reusable) - Global Industry Analysis, Size, Share, Growth, Trends, and Forecast 2018 – 2026, Transparency Market Research, Jan. 2019, <https://www.transparencymarketresearch.com/self-injection-device-market.html>.
2. Blindness and vision impairment, World Health Organization, Oct. 11, 2018, <https://www.who.int/news-room/fact-sheets/detail/blindness-and-visual-impairment>
3. The Future of Ophthalmology Drugs Market, Grand View Research, <https://www.grandviewresearch.com/research-insights/future-ophthalmology-drugs-market>.
4. Global Intravitreal Injectables Market - Growth, Future Prospects, Competitive Analysis, 2018 – 2026, Credence Research, Inc., April 1, 2019, <https://www.marketwatch.com/press-release/intravitreal-injectables-market-2018-2026-size-share-and-forecast-credence-research-2019-04-01/>.



30 years of uniting the entire Pharma value chain

The world's largest pharmaceutical exhibition, CPhI Worldwide houses six zones representing each stage of the pharmaceutical supply chain – from APIs, machinery, finished formulations and packaging to outsourcing and biopharmaceuticals.

Uniting over 2,500 international exhibitors, CPhI Worldwide is the place to network and source cost effective pharma solutions from all over the world – in just 3 days, under one roof.

REGISTER NOW! Visit gotocphi.com/ddd

Meet, network & learn



165+

Countries Participating



2,500+

Exhibiting Companies



100

Hours of Free On-site Content



Everybody here is seriously doing business, looking for business contacts and actively engaging."

Juan Sarmiento, Nemera



INTRATUMORAL DELIVERY

Arming the Immune System; Turning Cold Tumors Hot

By: Daniel J. O'Connor

INTRODUCTION

Finding a cure for cancer has been the foremost goals of researchers for decades. It's like archeologists searching for the Holy Grail or the lost city of Atlantis. Only today, science continues to make progress in this fight, exploring a variety of theories and pathways toward a seemingly elusive finish line.

Lately, research into immunotherapies have taken center stage; seeking to utilize one's own immune system to attack the cancers. CAR-T cells, vaccines, and checkpoint inhibitors have all shown some levels of success by shrinking cancerous tumors, slowing down, or in some cases, halting cancerous growth, all with a central focus of prolonging lives.

In recent published reports, it was noted that about 240 new vaccines and immunotherapies were in clinical trials as of mid-2017. Moreover, there were over 750 trials testing combinations of chemotherapy and immunotherapies.

Within the immunotherapy landscape, checkpoint inhibitors - antibody agents that mobilize the body's T-cell response - have moved front and center with a handful - KEYTRUDA®, OPDIVO®, and Yervoy® - receiving FDA clearance. However, despite the clinical and now market success of checkpoint inhibitors, the technology has thus far helped only a relatively small number of patients in certain cancer indications.

A recent blog post from the Dana-Faber Cancer Institute best describes a key challenge with cancer that appears to limit the effectiveness of immunotherapy technology:

"Hot tumors often have a high mutational load. That is, they have many changes in their DNA code that cause the cancer cells to produce distinctive new molecules called 'neoantigens' on their cell surface. These neoantigens make the tumor more prone to recognition by the immune system, and thus more likely to provoke a strong immune response. 'Cold' tumors, by contrast, are cancers that, for various reasons, haven't been recognized or haven't provoked a strong response by the immune system. Immune T cells have been unable to penetrate such tumors. The T cells have been excluded by components of the microenvironment. The microenvironment in and around tumor cells comprises blood vessels, structural elements, and specialized immune cells; the latter include myeloid-derived suppressor cells and regulatory T cells, or Tregs."

Checkpoint inhibitors work by releasing the brake on the immune system. As such, these drugs are most effective against "hot" tumors already studded with T cells and other immune cells. "Cold" tumors are largely resistant to checkpoint inhibitors because they lack significant engagement by immune cells. So the question is now, how do you correctly turn cold tumors hot?

TURNING "COLD" TUMORS "HOT"

Cytokines are molecular messengers that allow the cells of the immune system to communicate with one another to attack a target antigen in a coordinated, robust, but self-limited response. Doing so, cytokines enable the rapid propagation of immune sig-

Meet enFuse.™

An Innovative
On-Body Infusor.



Actual Size

naling in a multifaceted and efficient manner.

High-dose interleukin-2 (IL-2), a cytokine, was the second immunotherapy approved by the FDA to be used as a primary or stand-alone cancer treatment (the first was Interferon-alpha or IFN α). Though proven to be an effective regimen for metastatic melanoma, systemic high-dose IL-2 is also associated with toxicities. Because of intolerable side effects, most patients do not receive 100% of the planned dosing in a full cycle or course of high-dose IL-2.¹

Recognizing the shortcomings of high-dose IL-2, researchers are exploring novel delivery approaches that minimize the need to administer high doses of systemically delivered cytokines in order to improve safety while potentially enhancing effectiveness. In preclinical and clinical studies, intratumoral delivery of DNA-based interleukin-12 (IL-12 -tavokinogene telseplasmid; tavo) by way of intratumoral, avoids the toxicity of systemic immune stimulation.

A small hand-held applicator delivers a pulsed electric field to cells which temporarily increases the permeability of cell membranes (electroporation). Tavo is then delivered to the electroporated cells, which triggers each cell to produce and secrete IL-12 protein, which then identifies and eliminates cancer cells as part of a natural immune response.

The treatment is designed to produce a controlled, localized expression of IL-12 in the tumor microenvironment, which in turn, enables the immune system to target and attack tumors throughout the body. Currently, tavo is being investigated for treatment of metastatic melanoma and triple negative breast cancer. However, data has been encouraging enough to suggest a broad range of applications of tavo and to pursue combination therapies aimed at potentially addressing the 70% of cancer indications in which checkpoint inhibitors have lacked efficacy due to inhospitable – “cold” – tumor conditions that are devoid of CD8+ T cells.

TURNING UP THE HEAT ON MELANOMA

One area where this treatment regime could succeed is melanoma, a type of skin cancer that becomes more difficult to treat once it spreads beyond the skin, such as to the lymphatic system or visceral organs (metastatic disease). Although melanoma is a rare form of skin cancer, it accounts for more than 75% of skin cancer deaths. The poor prognosis of advanced melanoma is in part due to the limited therapeutic options available. Surgery and radiotherapy provide mainly palliation, and chemotherapy, most commonly with dacarbazine, has failed to show any consistent survival benefit.²

Given its occurrence in young individuals, the potential years of life lost to melanoma can be higher when compared with other cancers. The American Cancer Society estimates that approximately 87,000 new melanoma cases and 10,000 deaths from the disease will occur in the US in 2018. Additionally, the World

FIGURE 1



1. Cancer is identified in the body.
2. DNA-based IL-12 (tavo) is injected directly into the tumor.
3. The applicator supplies a sequence of short-duration electrical pulses through a series of needles.
4. Electrical pulses result in increased permeability of the cell membrane, allowing DNA-based IL-12 to enter.
5. IL-12 is expressed in the local tumor microenvironment.
6. IL-12 drives local inflammatory response in the tumor.
7. Immune cells are educated to recognize the patient's cancer.
8. Educated immune cells identify and attack tumors throughout the body.

“Recognizing the shortcomings of high-dose IL-2, researchers are exploring novel delivery approaches that minimize the need to administer high doses of systemically delivered cytokines in order to improve safety while potentially enhancing effectiveness. In preclinical and clinical studies, intratumoral delivery of DNA-based interleukin-12 (IL-12 - tavokinogene telseplasmid; tavo) by way of intratumoral, avoids the toxicity of systemic immune stimulation.”

Health Organization (WHO) estimates that approximately 132,000 new cases of melanoma are diagnosed around the world every year.

Tavo is currently being studied in combination with an anti-PD-1 therapy pembrolizumab (KEYTRUDA®) to treat patients with stage III/IV metastatic melanoma who have failed or are failing on anti-PD-1 therapies delivered as a monotherapy. Initial clinical studies demonstrated a clear potential, with the combination of tavo and pembrolizumab showing a 50% best overall response rate (BORR) in metastatic melanoma patients predicted not to respond to anti-PD-1 therapies alone.

Based on those data, OncoSec conducted a Phase 2 study involving 22 patients with melanoma predicted to be unresponsive to checkpoint inhibitors via observation of TIL status, PD-L1 expression, and IFN-g signature (three different biomarker assays). All patients were treated with a series of pulsed tavo injections directly into their lesions followed by standard intravenous delivery of

pembrolizumab.

After 24 weeks, the overall response rate to the tavo/pembrolizumab combination therapy was 43% (9/21) by RECISTv1.1 – 10% higher response rate than typically seen with pembrolizumab alone in a non-selected (“all-comers”) melanoma cohort. Nine patients achieved a complete response (38%) with only one patient having a partial response. (Another patient had an initial delayed response, was stable at 6 weeks and achieved a partial response at 24 weeks.) It is critical to note that these patients were very unlikely to respond to pembrolizumab at all, which makes the response rate even more striking.

We have demonstrated that tavo turns these cold tumors hot by promoting the generation of antigen-specific cells, triggering the PD-1 immune checkpoint, and providing the “substrate” for effective anti-PD-1/PD-L1 therapy.

The next clinical trial proposed by OncoSec will also evaluate the combination of tavo and pembrolizumab but enroll only

patients with melanoma that failed to respond to anti-PD-1 checkpoint inhibitors – a significant step toward potential FDA approval.

TREATING TRIPLE NEGATIVE BREAST CANCER

Applying the tavo combination approach to Triple Negative Breast Cancer (TNBC) has produced some encouraging preliminary observations. Like those suffering from late-stage melanoma, it’s well-documented that less than 5% of patients with heavily pretreated metastatic TNBC will respond to anti-PD-1 checkpoint therapies. In a study designed to determine whether tavo would elicit a pro-inflammatory molecular and histological signature in treated as well untreated sites in patients with inoperable locally advanced or recurrent TNBC, compassionate use of nivolumab (OPDIVO®), a checkpoint inhibitor treatment, was given to two patients at the investigator’s initiative 30 days after

being treated with one cycle of tavo. The observed responses – including tumor reduction and positive outcomes in both treated and untreated lesions – were remarkable and unexpected. This indicates a high probability that IL-12 primed the tumor environment and impacted the clinical result.

THE POWER OF PARTNERSHIPS

Combination therapy, a treatment modality that combines two or more therapeutic agents, is a cornerstone of cancer therapy.³ Combining treatments that have different mechanisms of action can kill more cancer cells and reduce the chance that drug resistance will emerge. The overall goal is to improve a patient's response to therapy without substantially increasing toxicity.⁴ When companies explore novel delivery methods, like electroporation, the positive effect on efficacy and safety can be increased even more. Collaborations between drug developers is critical to advancing cancer treatments like immunotherapy – and the field of immune-oncology overall – and to moving the world closer to a cure.

OncoSec's clinical trial collaborations, with drug innovators, such as Merck (KEYTRUDA®) and Bristol Myers Squibb (OPDIVO®), provide a clear illustration how combining therapeutic approaches can create a whole that's worth more than the sum of its parts. After all, the battle between cancer and the immune system is a complex mix of activity and inhibition. The key to improving patient outcomes is to combine treatments that stimulate the immune system and limit the tumor's ability to evade immune detection.

The results thus far should give every-

one great hope for the future. However, much work remains to further improve and extend immunotherapy's benefits.

CONCLUSION

On the pathway toward drug discovery, we often know where we want to go. But sometimes the challenge is finding a way to get there. When it comes to utilizing the human immune system to fight cancer, we believe we have discovered a platform that works. And now that we know a trigger mechanism that can turn cold tumors hot, researchers can set their focus on delivering potentially life-saving drugs directly to core of a cancerous tumor by blocking the cancer cells from turning off the body's natural immune system, and allowing it to attack the tumor from within.

Tavo, in combination with KEYTRUDA® and OPDIVO®, is showing promise in doing just that. Early clinical data shows that tavo combination therapy can slow down, stop, and reverse certain solid tumor cancers. Success here not only holds promise to treat today's cancer patients, but provides the key that may unlock the door to treating other types of cancer down the road. ♦

REFERENCES

1. <http://www.cancernetwork.com/renal-cell-carcinoma/managing-toxicities-high-dose-interleukin-2>.
2. <https://www.ncbi.nlm.nih.gov/pmc/articles/PMC5580705/>
3. <https://www.ncbi.nlm.nih.gov/pubmed/28410237>

4. <https://www.cancer.gov/about-nci/budget/plan/treating/combining-therapies>

To view this issue and all back issues online, please visit www.drug-dev.com.

BIOGRAPHY

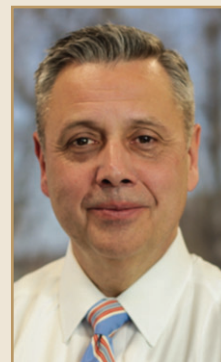

Daniel J. O'Connor is President and Chief Executive Officer of OncoSec Medical, a biotechnology company pioneering new technologies to stimulate the body's immune system to target and attack cancer. Additionally, he is currently the Vice Chairman of BioNJ and was recently nominated to serve on the New Jersey Biotechnology Task Force. Throughout his nearly 20 years in the biotechnology industry, he has utilized his combination of executive, legal, and regulatory experience in the biopharmaceutical industry to enhance the business and technological growth potential for several leading companies, including Advaxis, Inc., ImClone Systems, Bracco Diagnostics, Inc., and PharmaNet, now known as inVentiv Health. Prior to joining OncoSec, he was the President, Chief Executive Officer and Director of Advaxis, Inc., transforming it into a leading cancer immunotherapy company with collaboration partners including major biopharmaceutical manufacturers, such as Amgen Inc., Merck & Co., Bristol Myers Squibb, and AstraZeneca. Mr. O'Connor graduated Penn State University's Dickinson School of Law in Carlisle, PA, and currently serves as a special advisor to its Dean.



- Integrated Data
- Powerful Analysis Tools
- Industry Knowledge

Since 2003, PharmaCircle has been supporting Pharmaceutical Development & Innovation, providing clients with the integrated data, powerful analysis tools, and industry knowledge needed to solve complex, real world challenges in drug delivery and formulation.



The Difference is in the Details

www.pharmacircle.com

Drug Development EXECUTIVE



Bob Ward

Chairman & CEO

Eloxx Pharmaceuticals, Inc.



Eloxx Pharmaceuticals: Developing Rare Disease Drugs for Nonsense Mutations

Led by a management team experienced in the development of rare disease therapeutics, Eloxx Pharmaceuticals is a clinical-stage biopharmaceutical company dedicated to the discovery and development of novel therapeutics to treat cystic fibrosis (CF), cystinosis, inherited retinal disorders, and other diseases caused by nonsense mutations limiting production of functional proteins. *Drug Development & Delivery* recently interviewed Bob Ward, Chairman and CEO at Eloxx Pharmaceuticals, to discuss nonsense mutations and how his company's goal is to bring safe and effective therapies to children and adults suffering from genetic diseases as quickly as possible.

Q: What are nonsense mutations, and what is Eloxx working on to address the rare diseases associated with them?

A: Worldwide, approximately 4% of all babies are born with a genetic disease or major birth defect. Of those, about 12% of all mutations reported are caused by an anomaly known as a nonsense mutation. These variations introduce premature stop

codons in the reading frame of a gene, which can halt or stunt the production of a protein. Consequently, most nonsense mutations result in missing or nonfunctional proteins.

Nonsense mutations have been identified in about 1,800 rare and ultra-rare diseases, often patients with these mutations lack the ability to make essential proteins and have few, if any, treatment options. The vast

“Our research and development strategy is to target rare or ultra-rare diseases in which a high unmet medical need, nonsense mutation bearing patient population has been identified. We focus on clinical indications in which established preclinical read-through or personalized medicine experiments are predictive of clinical activity, and there is a definable path for Orphan Drug development, regulatory approval, patient access, and commercialization.”

majority of these are terrible diseases.

Our lead investigational compound, ELX-02, is in the early stages of development for CF and has the potential to be the first disease-modifying therapy for CF patients with nonsense mutations in one or both alleles. Preclinical studies have demonstrated that ELX-02 is a potent read-through-inducing drug in several models of genetic disease caused by nonsense mutations, including CF, cystinosis, mucopolysaccharidosis type I (MPS I), Rett syndrome Duchenne muscular dystrophy, and inherited retinal disorders. ELX-02 is an investigational drug that has not been approved by any global regulatory body.

Eloxx’s preclinical candidate pool consists of a library of novel ERSG drug candidates identified based on read-through potential. Eloxx recently announced a new program focused on rare ocular genetic disorders.

Q: What is your lead candidate, and review for our readers what is in the pipeline?

A: Our lead investigational compound, ELX-02, is a eukaryotic ribosomal selective glycoside (ERSG) designed to restore the production of protein through reading-through a premature stop codon and enabling the production of sufficient amounts of full-length functional CFTR protein to restore activity.

Currently our clinical programs for ELX-02 are focused on development for CF and cystinosis patients with diagnosed nonsense mutations on one or both alleles. These patients have

a high unmet medical need, a high burden of disease and few, if any, treatment options. Our CTA in Belgium for CF has been approved, and our IND in the US for cystinosis is open. Our Phase 2 program has been given a score of “high priority” by the European Cystic Fibrosis Society-Clinical Trial Network (ECFS-CTN). We expect to initiate Phase 2 clinical trials in CF and cystinosis and report top line data in 2019.

Eloxx’s preclinical candidate pool consists of a library of novel ERSG drug candidates identified based on read-through potential. Eloxx recently announced a new program focused on rare ocular genetic disorders.

We are the leader in the development of eukaryotic ribosomal selective glycosides (ERSG) aimed at treating rare and ultra-rare premature stop codon diseases.

Q: Can you review Eloxx’s current R&D strategy?

A: Our research and development strategy is to target rare or ultra-rare diseases in which a high unmet medical need, nonsense mutation bearing patient population has been identified. We focus on clinical indications in which established preclinical read-through or personalized medicine experiments are predictive of clinical activity, and there is a definable path for Orphan Drug development, regulatory approval, patient access, and commercialization.

Our current clinical focus is on CF and cystinosis where we are advancing our lead investigational drug candidate, ELX-02,

a eukaryotic ribosomal selective glycoside (ERSG). Eloxx's preclinical candidate pool consists of a library of novel ERSG drug candidates identified based on read-through potential. Eloxx recently announced a new program focused on inherited retinal disorders.

Q: What types of other diseases could Eloxx Pharma's platform potentially target?

A: More than 1,800 genetic diseases involve nonsense mutations that impair the production of essential proteins. Translational read-through is directed at restoring the production of full length functional proteins by overcoming the premature stop codon and the associated nonsense-mediated decay.

Q: What are organoids, and what is Eloxx doing with them from a research standpoint?

A: Organoids are tiny, self-organized three-dimensional tissue cultures that are derived from patient stem cells. The HUB, a nonprofit organization associated with the Utrecht University, has developed the organoid model and is testing all drugs approved and in development of CF. Eloxx is working with the HUB on a series of studies using CF patient-derived organoids and an FIS swelling assay, which is being broadly used in CF as a complement to the human bronchial epithelial cell model to understand how different cystic fibrosis mutations respond to ELX-02.

At the North American Cystic Fibrosis Conference (NACFC) in Denver this past October, we shared new data generated in the organoid model that demonstrates the reproducibility of the assay and its dependence on CFTR activity. ELX-02 is the first investigational compound to show these beneficial effects in organoids derived from patients with nonsense mutations. At NACFC, we shared positive data demonstrating that ELX-02 showed dose responsive increases in CFTR function and mRNA expression when tested in a correlative assay using organoids from CF patients with homozygous and heterozygous nonsense

mutations. The FIS swelling was consistent across a range of concentrations of the swelling-inducing agent, forskolin, and did not saturate in the timeframe of the assay. Significant dose-responsive increases in CFTR were demonstrated for ELX-02 in a functional assay using nanoString™ technology. ELX-02 mediated organoid swelling was found to correlate with increased CFTR mRNA, with elevations to levels at or above wild-type. ELX-02 appears to increase the steady state concentrations of CFTR mRNA, suggesting that ELX-02 may be modulating nonsense-mediated decay.

We are encouraged by the data that showed it is possible to restore CFTR and mRNA to normal levels in patients with nonsense mutations with ELX-02 to normal levels. These data are important as mRNA is required by the cell to make CFTR protein. By enabling read-through, mRNA is no longer being degraded by nonsense-mediated decay.

Q: What are the next critical steps for Eloxx?

A: We're pleased that our CTA in Belgium for CF is approved and that ELX-02 has been granted Orphan Drug Designation by EMA. Our IND for the US for cystinosis is open, and the FDA has also granted ELX-02 Orphan Drug Designation.

We expect to initiate Phase II trials this year, and we are on track to report top line data in 2019. We are very encouraged, as ELX-02 is the only read-through agent to have demonstrated substantial activity in CF patient-derived organoids bearing nonsense mutations. We believe the consistent positive data meaningfully de-risk our planned Phase II studies.

We're pleased to have initiated a new program focusing on inherited retinal diseases and with the emerging favorable tolerability profile demonstrated by several compounds from our library, We are currently in IND-enabling studies and plan to advance an additional molecule into development in an inherited retinal disorder, and we have entered into a broad strategic partnership with the Foundation Fighting Blindness. ♦

To view this issue and all back issues online, please visit www.drug-dev.com.



Nemera

**Patient-focused
drug delivery devices**

Drug Delivery Devices
Innovative developments
Customized solutions
GMP customer IP manufacturing

we put
patients
first

www.nemera.net
information@nemera.net
Phone: +33 (0)4 74 94 06 54



BIOLOGICS DELIVERY

Enabling Biologic Drug Delivery of Volumes Beyond 1 mL

By: Megan Lan, and Patrick Le Gal

ABSTRACT

Patients affected by chronic diseases commonly require regular injections of biologics, and many opt for self-injection. However, a wide range of biologics used to treat chronic diseases are now developed in volumes higher than 1 mL, requiring changes to the self-injection devices previously available. As the biological drug design space evolves toward formulations with larger dose volume and higher viscosity, the device industry is adapting by developing more innovative delivery systems. To accommodate these advances, delivery system manufacturers need to use methodologies and tools to manage conflicting requirements and to offer delivery solutions that balance performance, robustness, and usability while delivering higher volume or viscosity biologics. To support delivery of advanced biologics, BD offers safety systems, such as BD UltraSafe™ 2.25 mL passive needle guard, providing acceptable trade-offs to meet patient's needs, such as easy-to-use, comfortable, and safe for its intended use.

INTRODUCTION

The increasingly challenging therapies in development to treat chronic diseases are raising the bar for injection delivery technology performance to enable safe and effective pharmaceutical drug delivery. New usability issues associated with high-volume or high-viscosity formulations are requiring new technical innovations, such as large-volume autoinjectors, that enable performance beyond the traditional design space parameters (up to 2 mL and beyond).

High volume injections are becoming more challenging due to increased force required to inject the pharmaceutical drug within target injection time limits – limits that do not increase with larger dose volumes. Because of this, delivery systems that are safe, intuitive, easy to use, and appropriate for the target user population (which may have manual dexterity limitations) while capable of higher forces within the same injection time constraints are increasingly necessary.

Self-injections have traditionally been delivered in the form of autoinjectors, which reduce the force required by the user. By supplying extra force to the injection mechanism through internal design, autoinjectors have reduced the burden on patients to inject themselves with medication. However, not all therapeutic areas and patients are well suited to use autoinjectors. In some cases, patients prefer to manually control the injection rate.¹ This may be due to perceived pain, a preference for greater control, or simply a desire to apply their medication with no external assistance.

From these trends, a question that arises is whether emerging biologic therapies that are formulated in the 1 to 2 mL dose delivery design space may also be delivered manually to address the needs of patients who prefer to retain manual control of injection. The following is a review of human factor data as well as packaging and drug delivery factors that should be considered when formulating drug therapies that are moving beyond the traditional subcutaneous dose volume delivered of 1 mL.

PODD

PARTNERSHIP OPPORTUNITIES IN DRUG DELIVERY

October 7-8, 2019 • Renaissance Boston Waterfront Hotel • Boston, MA

CONFERENCE CHAIR AND KEYNOTES



Katherine High, MD
Spark Therapeutics

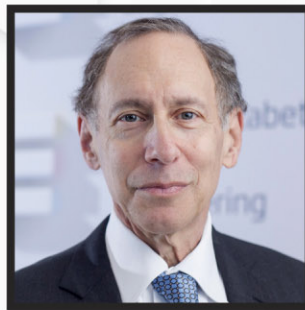

Robert Langer, PhD
MIT

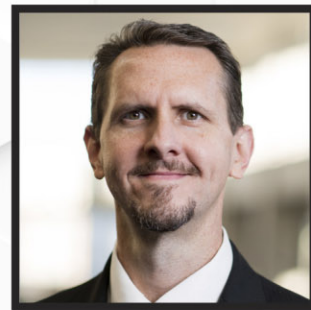

Allen Templeton, PhD
Merck

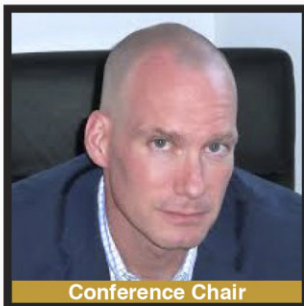

Shawn Davis, PhD
AstraZeneca



Giovanni Traverso, PhD
MIT / Brigham and Women's
Hospital, Harvard Medical School



Sangeeta Bhatia, MD, PhD
MIT

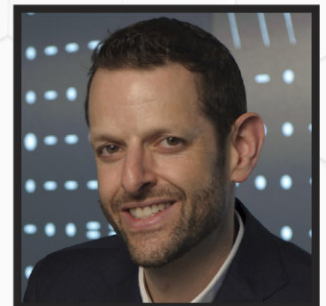

Jeffrey Karp, PhD
Harvard Medical School /
Brigham and Women's Hospital

FEATURED BENEFITS

- Access to **90+ speakers**
- Access to **375+ attendees**
- **Access to exhibit floor** featuring a diverse range of drug delivery technologies and services.
- **8+ hours of networking** with key decision makers from pharmaceutical, biotechnology, and drug delivery companies.

USE THE CODE **DDD15**
FOR A **15% DISCOUNT**

LEARN MORE AT: THECONFERENCEFORUM.ORG

FIGURE 1

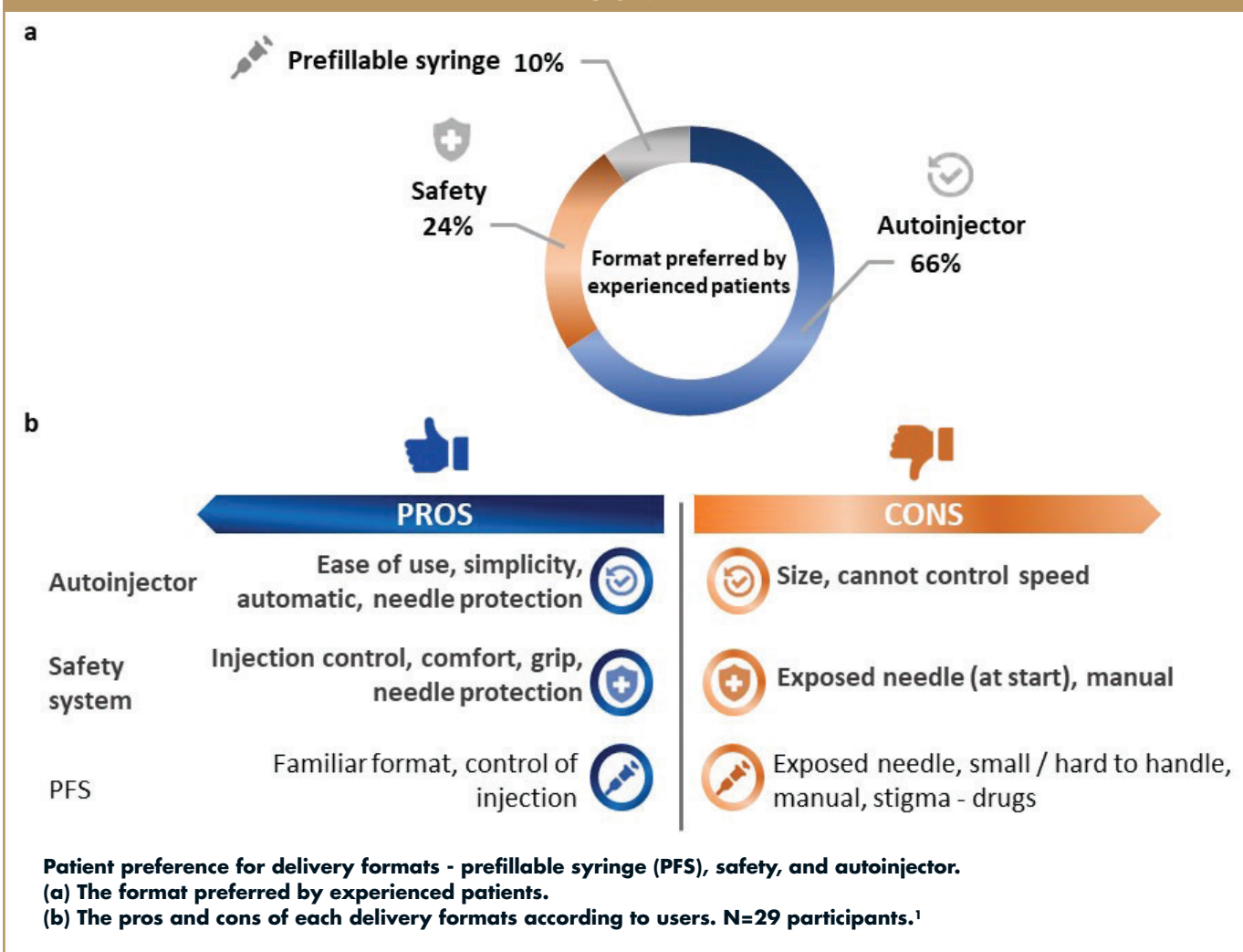

THE CHALLENGES OF BIOLOGICS FORMULATION & DELIVERY FOR CHRONIC DISEASES

In the field of chronic diseases, biologics are increasingly developed in high-dose formats, yielding high injection volumes (up to 2 mL and beyond) or viscosities (up to 30 cp and more). From the pharmaceutical manufacturer perspective, biologics are facing formulation challenges due to many conflicting requirements, particularly as they are now moving beyond 1-mL dose volume.

To achieve desired performance with a high-volume delivery system, acceptable trade-offs must be made between the following requirements:

- Large molecules, such as complex proteins should be formulated to increase target specificity.
- The drug should be sufficiently dosed to achieve the targeted efficacy.
- The liquid form should be stable enough to enable an easy process of self-injection at home by patients or caregivers, without drug reconstitution steps.
- Low viscosity range should be achieved to enable easy manufacturing (filling) and storage and to decrease the force required to deliver the solution.
- Injection time, force, ease of use, and handling comfort should support patient adherence to the therapeutic.

Biologics for subcutaneous injection may be highly concentrated, which can lead to high viscosity and can raise concerns of potential drug destabilization, due to aggregation of the molecules.² Manageable viscosity can be achieved by lowering concentration; however, this can require a higher dose volume. Consequently, this could create difficulties for self-injecting patients due to increasing injection times and injection forces.

Drawing on this, some points should be considered in order to make high-vol-

FIGURE 2

BD UltraSafe Plus™ passive needle guard* One-handed, passive activation

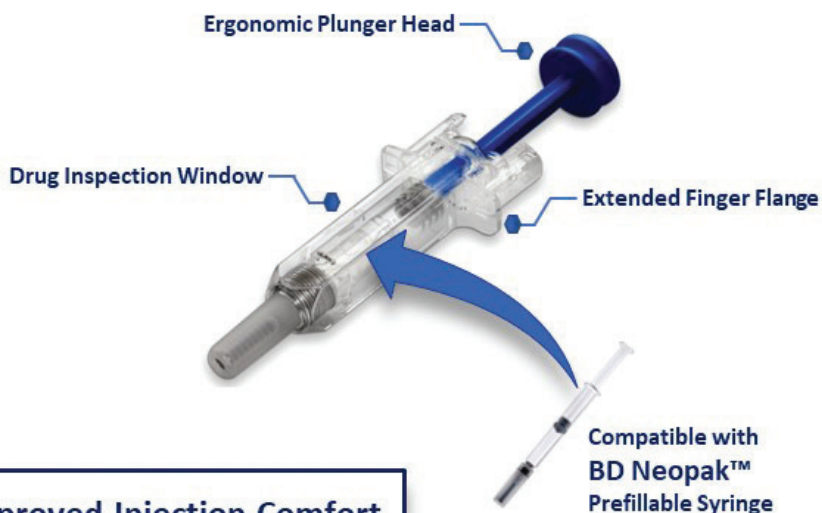
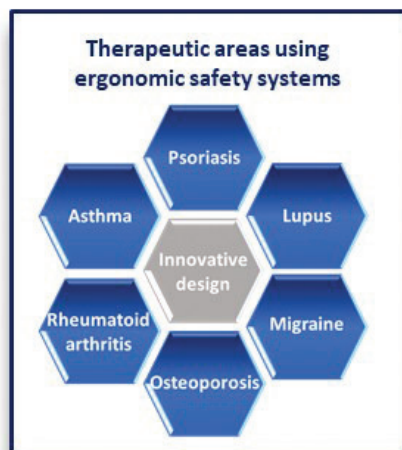

Improved Injection Comfort
Compared to standalone syringe⁶

*BD UltraSafe Plus™ 2.25 ml passive needle guard is a product that is in development; some statements made are forward-looking that are subject to a variety of risks and uncertainties.

BD UltraSafe Plus™ Passive Needle Guard

ume delivery possible. First to consider is how to minimize the complexity of the injection technology? Another crucial point is the patients' capability: will they accept a larger injection? Is it still possible for them to inject themselves manually or will the higher force and injection time negatively impact the patient's adherence to treatment? Considering the packaging selection process, it is essential to select a primary container technology, such as the prefillable syringe, as soon as possible in biologic drug development while the final dosing and delivery format may not be fixed until the end of Phase 2. Yet the choice of patient delivery system may be inadvertently constrained by the choice of primary packaging. How can delivery system flexibility best be maintained during combination product development in order

to facilitate patients' ease of use while reducing risk to the drug development timeline?

Fortunately, the delivery system landscape is evolving to meet the needs of biotech companies, with multiple products in development to serve higher volume and higher viscosity biologics.

For instance, BD develops a variety of customizable patient self-injection systems, including autoinjectors, safety and shielding systems, and wearable injectors to serve current and emerging delivery needs. BD UltraSafe 2.25 mL passive needle guard is one example of a new solution that meets evolving pharmaceutical needs for biologics delivery.

DESIGNED FOR AN EASY SELF-ADMINISTRATION OF VOLUMES BEYOND 1 ML

Patient preference and sophistication concerning self-injection delivery systems is changing as well. BD's qualitative research with self-injection experienced users showed that while more subjects used autoinjectors and prefillable syringes than safety systems at 62%, 31%, and 7% respectively, autoinjectors and safety systems were ranked No. 1 and No. 2 in terms of patient preference over stand-alone syringes the majority of the time (81%).¹ Today, patient preference for delivery formats is evolving, and ergonomic safety solutions are becoming more prevalent for patients who prefer manual control of injection (Figure 1a).¹ Figure 1b summarizes

the pros and cons of the different delivery formats according to patients.¹ Therapeutic areas that now utilize ergonomic safety systems for manual injections include rheumatoid arthritis, psoriasis, atopic dermatitis, asthma, and migraine among others.³

To support patients who prefer manual control of injection, BD has expanded its BD UltraSafe product range to work with prefillable syringes, such as BD Neopak™

2.25 mL prefillable syringe (Figure 2).⁴ According to Tzvetelina Chevolleau, PhD, Clinical and Human Factor Program Leader, “as high-dose biologic formulations push current limits of self-injection into 1 to 2 mL formats and beyond, delivery systems that are intuitive and easy to use and targeted to specific user populations are becoming increasingly necessary.” While self-injection systems are often provided in the form of autoinjectors, manual

injections, when given in an appropriate delivery format, can feasibly deliver injections that push the boundaries of volume or viscosity.^{5,6}

With the BD UltraSafe™ 2.25 mL passive needle guard system, BD has addressed manual injections of volumes beyond 1 mL and conducted a human factors study to evaluate the usability, ease of use, and acceptance of this new system compared to injection with stand-alone

FIGURE 3

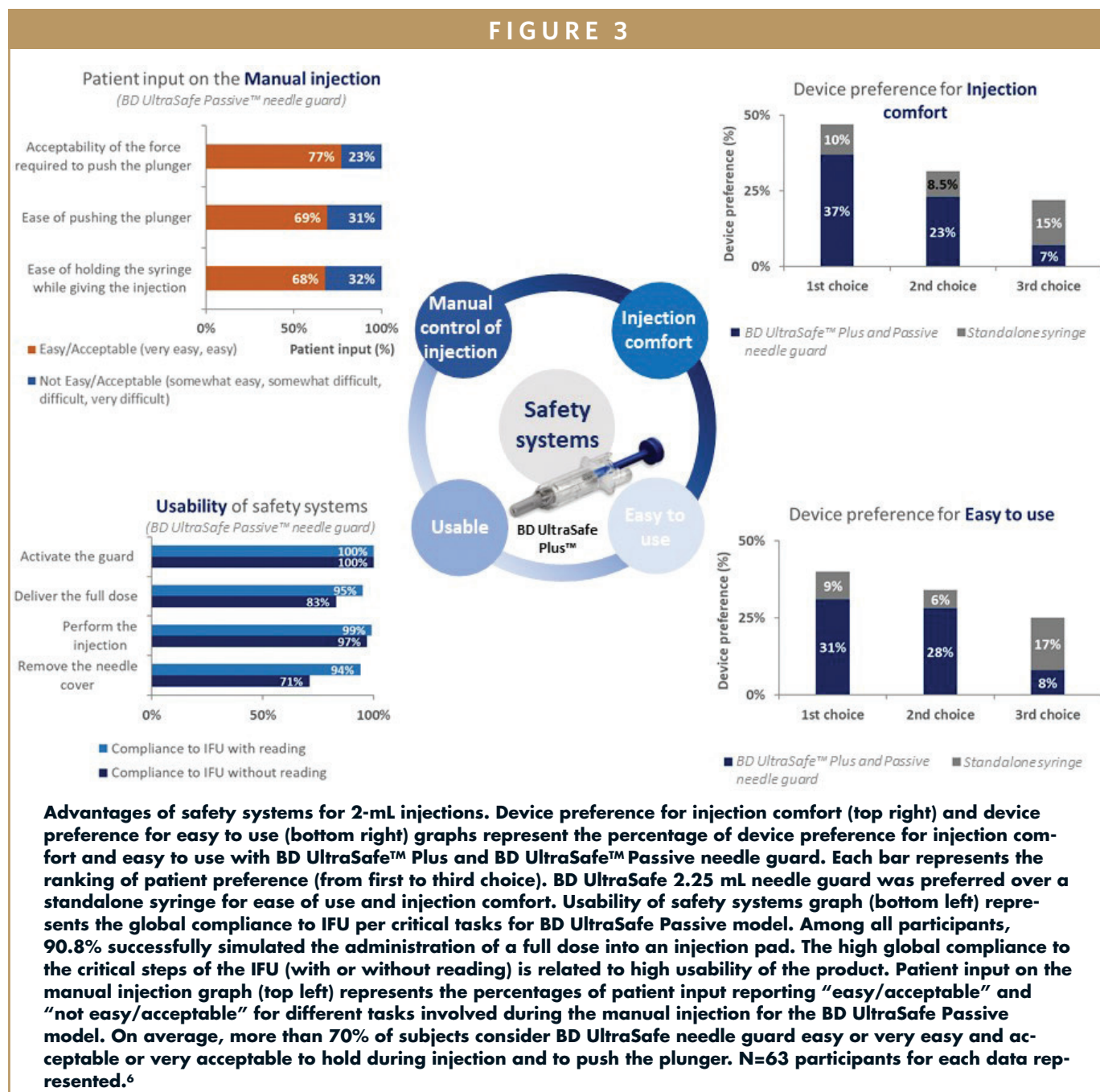

aaps PharmSci 360®

November 3–6, 2019
San Antonio, Texas

Henry B. Gonzalez Convention Center

**Advancing Pharmaceutical Sciences,
Careers, and Community**

DISTINGUISHED PLENARY SPEAKERS

(Photo by: Will Kirk, Johns
Hopkins University)

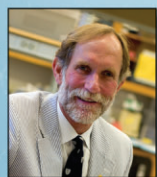

Peter Agre, M.D., co-recipient of the 2003 Nobel Prize in Chemistry, Bloomberg Distinguished Professor, and Director, Johns Hopkins Malaria Research Institute



Vivek H. Murthy, M.D., MBA, 19th Surgeon General of the United States

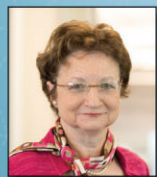

Katherine High, M.D., President, Spark Therapeutics, led the development of the first gene therapy for a genetic disease in the United States

Plus, notable keynote speakers will take part daily in dialogue covering each of the meeting's 5 tracks.

Hear them all—register NOW!

**Advance Registration
Deadline: October 9**

www.aaps.org/pharmsci360

“High volume injections are becoming more challenging due to increased force required to inject the pharmaceutical drug within target injection time limits – limits that do not increase with larger dose volumes. Because of this, delivery systems that are safe, intuitive, easy to use, and appropriate for the target user population (which may have manual dexterity limitations) while capable of higher forces within the same injection time constraints are increasingly necessary.”

prefilled syringes.⁷ This study on 63 subjects demonstrates that on average, more than 70% of subjects consider this delivery system easy or very easy and acceptable or very acceptable to hold during injection and to push the plunger.⁶ Overall, users were able to properly manipulate it regardless of the “instructions for use” availability (with or without instructions), attesting to the ease of use of this product.⁶ According to the findings, BD UltraSafe 2.25 mL (Plus* and Passive systems) was preferred over a stand-alone syringe for ease of use and injection comfort.⁶ Most participants consider the time required to use this product acceptable. With this study on the BD UltraSafe 2.25 mL passive needle guard, BD provides evidence that it is easy to use, comfortable to hold and inject, and safe for its intended use (Figure 3).⁶

SYSTEM INTEGRATION OF COMBINATION PRODUCTS

Today, self-injection systems allow patients to receive their drugs ready-to-use, such as in prefilled injection devices. Prefilled systems limit manipulation of the drug

by the patient and therefore reduce the risk of error during the self-injection process compared to a vial and syringe.⁸

Drug-device combinations include autoinjectors, wearable injectors, safety systems, and prefilled syringes. To launch these complex systems, pharmaceutical companies must separately select, develop, and assemble multiple components to optimally work together in order to deliver a safe and effective drug formulation.

However, during combination product development with higher dose biologics, system conflicts may arise and may incur high costs. The typical sequence (selecting primary packaging during Phase 2, then developing the delivery system later when dosing is fixed or the preferred delivery presentation identified) may result in a need to modify the delivery system or possibly the primary container in case of incompatibility. In this case, a high cost based on resources and lost time may be incurred. The primary container with its intrinsic performance and integration attributes can critically affect delivery system performance, and this is why having a strategic partnership with delivery system and primary container manufacturer(s) is

essential.

Lionel Maritan, Research & Development Associate Director, states that “BD is committed to optimizing system integration of combination products to avoid problems related to poorly integrated systems, such as breakage, incompatibility, and non-performance encountered when different components are purchased from a variety of suppliers. This quality-by-design approach deployed at every interface between the drug, container, and delivery device can significantly reduce the risk of potential delay to launch timelines and financial loss.”

INTEGRATED SYSTEM DEVELOPMENT: BD'S COMMITMENTS

To address these challenges and improve combination product system performance, BD dedicates deep R&D expertise and experience to design delivery systems. As one of the world's leading suppliers which offers both primary containers and secondary delivery systems, BD provides the assurance of a broad

FIGURE 4

Prefillable syringes

BD Neopak™ 2.25 mL Prefillable Syringe

BD Neopak™ Prefillable Syringe

BD Hypak™ for Biotech Prefillable Syringe

Safety systems

BD UltraSafe Plus™ Passive Needle Guard

BD UltraSafe Plus™ 2.25 mL* Passive Needle Guard

Autoinjectors

BD Intevia™ 1 mL and 2.25 mL Disposable Autoinjector*

BD Physioject™ Disposable Autoinjector

Wearable injectors

BD Libertas™ Wearable Injector*

*BD Libertas™, BD Intevia™, and BD UltraSafe Plus™ 2.25 mL are products in development; some statements made are forward-looking that are subject to a variety of risks and uncertainties.

The range of BD's integrated delivery systems.

array of expertise throughout the product development process, by working closely across technology platforms to define system interfaces from the early design phases through manufacturing strategy and execution. To benefit pharmaceutical companies, BD offers a solution that balances performance, robustness, and usability to meet the needs of biotechnology companies that are developing drug products which are increasingly challenged with a larger dosing volume and/or a higher viscosity.

Due to the complex combination product selection process described earlier, BD integrates the BD Neopak prefillable syringe technology for biologics into their self-injection systems, providing multi-platform flexibility to utilize innovative delivery solutions across a range of dose volumes and viscosities (Figure 4). With integrated

solutions, such as BD Libertas™ wearable injectors, BD Intevia™ disposable autoinjectors, and BD UltraSafe needle guards, pharmaceutical companies can take advantage of greater choice and flexibility to serve diverse patient groups, therapeutic areas, and markets with the appropriate delivery format. Finally, as BD Neopak may be used in combination with a broad range of secondary delivery systems, the costs associated with managing multiple component interfaces and suppliers can be minimized.

BD Neopak was specifically designed to address aggregation issues with sensitive biologics by minimizing drug/container interactions.^{6,7,9,10} In addition to conventional benefits of prefillable syringes (PFS), BD Neopak supports autoinjector performance with higher volume or viscosity biologics through tightly con-

trolled gliding and dimensional precision, tightened specifications, and low part-to-part variability.^{3,5} Supporting PFS performance within an autoinjector can allow pharmaceutical companies to contain costs and minimize risks.¹¹ Additionally, the BD Neopak portfolio of options covers a broad design space for enabling agile development and facilitating time to market. This platform is built on decades of BD's experience partnering with leading biopharmaceutical companies to support drug development and launch. BD Neopak was conceived with a solution-finding mindset, allowing pharma and biotech companies to tangibly meet current and future needs for biotech drugs.

SUMMARY

To address biologic development issues, BD is applying its knowledge base gained from a long history with combination products. With its portfolio of integrated systems, BD offers continuous process and service improvements to increase pharmaceutical companies' flexibility to meet patients' needs with the right delivery solutions. BD's integrated systems are intended to mitigate system performance risks, optimize cost savings, and prevent combination product launch delays. Considering the evolving biologic drug design space and shifting patient preferences, BD has developed high-volume, ergonomic safety solutions. BD has demonstrated through a human factors study that BD UltraSafe 2.25 mL passive needle guard is easy to use, preferred, and safe for its intended use. Manual systems, when provided in a suitable delivery format, can feasibly deliver injections that push the traditional boundaries of volume. ♦

** BD UltraSafe Plus™ 2.25 mL passive needle guard is a product that is in development; some statements made are forward-looking that are subject to a variety of risks and uncertainties.*

REFERENCE

1. Autoinjector patient preference market research [Qualitative research]. USA and UK; 2016.
2. Mathaes, Roman, et al. "Subcutaneous injection volume of biopharmaceuticals—pushing the boundaries." *Journal of pharmaceutical sciences* 105.8 (2016): 2255-2259.
3. Therapeutic areas and drug type using BD safety devices [Internal analysis]. Pont de Claix, FR: Becton Dickinson and Company; 2016.
4. Compatibility study of BD Safety UltraSafe Plus™ with BD 1ml long glass syringes [internal study]. Pont-de-Claix, FR: Becton, Dickinson and Company; 2014.
5. Simulated usability study of BD UltraSafe™ and BD UltraSafe Plus™ passive needle guard [internal study]. Pont-de-Claix, FR: Becton, Dickinson and Company; 2012.
6. Silicone quality and Silicone profile [Internal Study]. Pont-de-Claix, FR: Becton Dickinson and Company; 2013.
7. A Simulated Study of BD UltraSafe™ Needle Guard 2.25 ml devices [Internal study]. Pont de Claix, FR: Becton Dickinson and Company; 2014.
8. Global Value Dossier Vial to prefill product portfolio [Internal study]. Franklin Lakes, NJ USA: Becton Dickinson and Company; 2017.
9. BD Neopak™ Process verification [Internal Study]. Pont-de-Claix, FR: Becton Dickinson and Company; 2014.
10. BD Neopak™ 1 mL Long Term Verification: Glue Extractables [Internal Study]. Pont-de-Claix, FR: Becton Dickinson and Company; 2014.
11. Boehringer Ingelheim - Friedrich Haefele., *Translating a Quality by Design PFS Into Tangible Value for Biopharmaceuticals*. PDA Universe of Pre-filled Syringes and Injection Devices October 6-8, 2014.

BIOGRAPHIES



Megan Lan leads Global Marketing for the safety portfolio at BD Medical-Pharmaceutical Systems. She provides commercial leadership to BD's delivery system platforms and defines, develops, and launches patient-centered self-injection and safety systems in collaboration with cross-

functional, commercial, and regional teams. She has also developed pen injectors and autoinjectors and participated on ISO committees to improve standards influencing patient safety and usability. She previously served in public health and development with the Peace Corps in Central America and worked in product development at Kimberly-Clark Corporation. She earned her MBA and MA at the University of Pennsylvania and has an undergraduate degree in Biomedical Engineering.



Patrick Le Gal has been with BD Medical-Pharmaceutical Systems since 2006 in different roles in New Product Development and Innovation Management, working with pharmaceutical companies to develop and bring to market drug delivery solutions from prefilled syringes to complex injection systems.

He is a Mechanical Engineer by training (1993) and started his career in the automotive industry in various R&D positions, where he has focused on system integration, and also on elastomeric systems development and manufacturing. He is currently R&D Director for advanced drug delivery solutions at BD, such as safety systems, autoinjectors, pens, and wearable injectors, where his responsibilities include innovation, new product development, and sustaining activities.

Technology & Services SHOWCASE

PARENTERAL DELIVERY DEVICES



FOR BETTER TREATMENT OF CHRONIC DISEASES. Across the healthcare continuum, BD is the industry leader in parenteral delivery devices that help health systems treat chronic diseases. We not only continually advance clinically proven, prefillable drug delivery systems, we do so with a vision to help healthcare providers gain better understanding of how patients self-inject their chronic disease therapies outside the healthcare setting. This is why we partner with leading pharmaceutical and biotech companies worldwide to develop digitally-connected self-injection devices — including wearable injectors and autoinjectors — to capture valuable data that can be shared with caregivers. Discover how BD brings new ideas and solutions to customers, and new ways to help patients be healthy and safe. For more information, visit BD Medical – Pharmaceutical Systems at bd.com/Discover-BD1.

PLATFORM TECHNOLOGY

CAPTISOL®

Captisol is a patent-protected, chemically modified cyclodextrin with a structure designed to optimize the solubility and stability of drugs. Captisol was invented and initially developed by scientists in the laboratories of Dr. Valentino Stella at the University of Kansas' Higuchi Biosciences Center for specific use in drug development and formulation. This unique technology has enabled 11 FDA-approved products, including Onyx Pharmaceuticals' Kyprolis®, Baxter International's Nexterone®, and Merck's NOXAFIL IV. There are more than 30 Captisol-enabled products currently in clinical development. For more information, visit Captisol at www.captisol.com.

PARENTERAL DRUG PRODUCT SOLUTIONS



Catalent Biologics has over 20 years of experience in developing and manufacturing parenteral drug products for new biologic entities and biosimilars, including 20 commercially approved products through fill/finish. At its European and U.S. sites, Catalent provides specialized scientific support and manufacturing of complex sterile injectable treatments with a customizable range of liquid or lyophilized vials, pre-filled syringes, and cartridges. With its automated filling lines, including the highest degree of aseptic processing utilizing barrier isolator technology and restricted access barrier systems, Catalent's secondary packaging capabilities are integrated into its fill/finish operations. Catalent's drug product operations are dedicated to customer clinical and commercial project needs from development to finished product supply with access to world class expertise and state-of-the-art technology. For more information, contact Catalent Pharma Solutions at (888) SOLUTION or visit www.catalent.com.

DIFFERENTIATED INJECTABLE DELIVERY



Credence MedSystems is a medical technology company focused on delivering medications safely for the benefit of our patients, caregivers and partners. The Companion Safety Syringe System was born from Credence's core philosophy of *Innovation Without Change*. By providing passive safety and reuse prevention while using existing primary package components, the Companion offers best-in-class drug delivery with a vastly simplified path to market for our biotech and pharmaceutical partners. The Companion is available in luer needle, staked needle and dual chamber reconstitution configurations. In all cases, the user performs the injection, receives end-of-dose cues and then the needle automatically retracts into the syringe, which is then disabled. For more information, contact Credence MedSystems at 1-844-CMEDSYS, email info@credencemed.com, or visit www.CredenceMed.com.

Technology & Services SHOWCASE

TESTING SERVICES



Testing experts.
Service specialists.

DDL is an independent third-party, ISO 17025-accredited testing laboratory that provides package, medical device, and combination products testing. For nearly 30 years, DDL has provided extraordinary service and specialized testing expertise to the medical device and pharmaceutical industries. We employ a team of engineers, technical, and quality experts devoted to helping our customers bring medical device and combination products to market. Our single source, totally integrated approach enables organizations of all sizes from start-ups to globally recognized corporations maximize product performance, reliability, and safety while seamlessly achieving regulatory compliance. We work hard to build strong partnerships with our clients and have an unwavering commitment to assist in getting products to market on time. For more information, visit DDL at www.DDLTesting.com.

MEET enFUSE™



The **Enable Injections** enFuse™ is an on-body drug delivery platform with a self-contained drug transfer system compatible with standard syringes or vial container formats. The wearable enFuse platform is being developed for subcutaneous administration of large-volumes ranging up to 50 mL. Designed for ease of use, the enFuse has the potential to provide patients and their caregivers an alternative delivery method for subcutaneous administration of parenteral therapies outside of a clinical setting. In addition, the next-generation enFuse incorporates Bluetooth technology for remote patient monitoring, incorporated to improve adherence. Learn more about subcutaneous administration with the enFuse at <http://enableinjections.com/enFuse>.

DPI PORTFOLIO

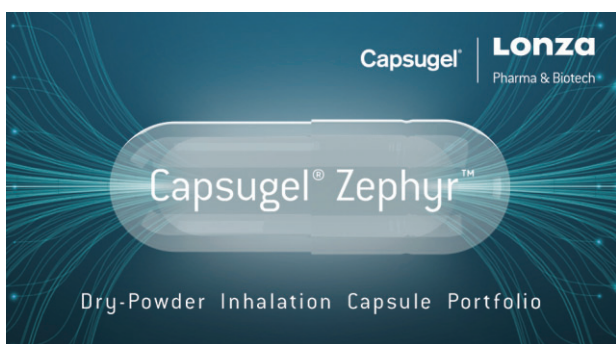

Dry-powder inhalation (DPI) technology offers a favorable drug development opportunity for respiratory or systemic drug delivery. Delivering a uniform dose in a portable, easy-to-use system, capsule-based DPI device is a simple and cost-effective way to deliver inhalable medication. Capsugel® Zephyr™ is Lonza's customizable dry-powder inhalation capsule portfolio that is optimized to provide superior performance and compatibility between the capsule/device and capsule/formulation. Please visit our page for more information or contact our experts to request samples at <https://www.capsugel.com/biopharmaceutical-products/dpi-capsules>.

FUNCTIONAL CHEMICALS



MITSUBISHI GAS CHEMICAL

Mitsubishi Gas Chemical (MGC) is a leading company in the field of functional chemicals, such as oxygen barrier and absorbing polymers. MGC established the Advanced Business Development Division in 2015 for tackling a variety of today's problems, and the division created OXYCAPT™ Multilayer Plastic Vial & Syringe to solve some issues of existing primary packaging for injectable drugs. OXYCAPT Vial & Syringe consists of three layers. The inner and outer layers are made of cycloolefin polymer (COP), the most reliable polymer in the pharmaceutical industry. The middle layer is made of state-of-the-art polyester developed by MGC. The oxygen-barrier property is almost equivalent to glass and much better than COP. OXYCAPT also provides an ultra violet (UV) barrier. For more information, visit Mitsubishi Gas Chemical at www.mgc.co.jp/eng/products/abd/oxycapt.html.

Technology & Services SHOWCASE

PATIENT-FOCUSED DELIVERY DEVICES

Nemera



With over 1,600 people and four plants across two continents, **Nemera** is a world leader in the design, development, and manufacturing of drug delivery devices for the pharmaceutical, biotechnology, generics industries. Nemera's services and products cover several key delivery routes: Ophthalmic (multidose eye droppers for preservative-free formulations), Nasal, Buccal, Auricular (pumps, valves, and actuators for sprays), Dermal & Transdermal (airless and atmospheric dispensers), Parenteral (autoinjectors, pens, safety devices, and implanters), and Inhalation (pMDIs, DPIs). Nemera always puts patients first, providing the most comprehensive range of devices in the industry, including off-the-shelf innovative systems, customized design development, and contract manufacturing. For more information, contact Nemera at information@nemera.net or visit www.nemera.net.

GLOBAL DATA & ANALYTICS



PharmaCircle is a leading provider of global data and analysis on the pharmaceutical, biotechnology, and drug delivery industries. PharmaCircle's premier database delivers an integrated scientific, regulatory, and commercial landscape view with unprecedented access to hundreds of company, product, and technology attributes. PharmaCircle connects product and pipeline information for drugs and biologics with formulation and component details, and provides due diligence level data on nearly 6,000 drug delivery technologies and devices. Drug label comparison tools and full-text document search capabilities help to further streamline research. No other industry database matches PharmaCircle's breadth of content and multi-parameter search, filtering, and visualization capabilities. To learn more, email contact@pharmacircle.com, call (800) 439-5130, or visit www.pharmacircle.com.

DEVICE TRAINING PLATFORMS

noble®

Noble works with drug delivery device manufacturers and biopharmaceutical companies to develop self-injection training devices, including autoinjectors, prefilled standard and safety syringes, wearables, and respiratory platforms to provide biopharmaceutical companies improvements in launch strategies and patient adherence. Noble's training and onboarding platforms are built true to form and function to device specifications and are available as off-the-shelf and customized solutions, with the optional inclusion of proprietary technologies for products ranging from mechanical training devices to smart error-correcting training platforms. These devices are designed to emulate a device's form factor and functionality, including tactile feedback, operational forces, and administration steps to provide patients with accurate simulation of actual delivery devices while being a low-cost reusable solution to safely and effectively onboard users. Companies providing reusable, device-comparable training products will be well positioned for competitive differentiation through improved patient satisfaction, adherence, and outcomes. For more information, contact Noble at (888) 933-5646 or visit www.gonoble.com.

NEEDLE-FREE INJECTION



Portal Instruments

Portal Instruments, a clinical-stage medical device company is developing a next-generation needle-free drug injection platform to transform the drug delivery experience for patients suffering from chronic diseases, such as ulcerative colitis, multiple sclerosis, rheumatoid arthritis, and psoriasis. Today, patients suffering from many chronic conditions have access to biologic drugs that can greatly improve their well-being. Unfortunately, those drugs must often be self-injected via a needle and syringe, which can lead to patient anxiety and uncertainty. In some cases, patients may refuse treatment or skip injections and then might not be able to reach the outcomes that they wish. For more information, visit Portal Instruments at www.portalinstruments.com.

Technology & Services SHOWCASE

ADVANCED DELIVERY DEVICES



SHL Group (Scandinavian Health Ltd) is a world-leading solution provider in design, development, and manufacturing of advanced drug delivery systems. We work with leading biotechnology and pharmaceutical companies to develop drug delivery devices, including compact disposable auto injectors, reusable pen injectors and complex inhaler systems. Significant investment in R&D has allowed us to enhance our broad pipeline of “next-generation” drug delivery systems. These include a range of disposable and reusable injectors with fixed or variable dosing, high dose accuracy, and the ability to accommodate high volumes and high viscosities. With locations in Taiwan, Sweden, China, and the US, our experienced engineers and designers develop product enhancements and breakthrough drug delivery solutions for pharma and biotech clients globally. For more information, visit SHL Group at www.shl.group.

VERSATILE PLATFORM



Sonceboz core competencies consist of design, development, and production of mechatronic drive systems. Since 1936, our focus has been on innovation, best-in-class quality, and service, which is our key to success for worldwide OEM customers. Sonceboz is ISO 13485 certified and active in wearable drug delivery, medical devices, and laboratory industry. Pharma companies looking for Large-Volume Injectors for high- viscosity drugs, Dual-Cartridge, or Auto-Reconstitution Injectors will find interesting solutions in Sonceboz’s new drug Delivery Device Platform. Sonceboz’s activity in medical devices is based on a long experience in industry, where top quality, reliability, and cost effectiveness is key. For more information, visit Sonceboz at www.medical.sonceboz.com.

FULL-SERVICE CDMO



Vetter is a leading contract development and manufacturing organization (CDMO) that specializes in the aseptic filling and packaging of syringes, cartridges, and vials. The company has extensive experience with biologics and other complex compounds, including monoclonal antibodies, peptides, interferons, and vaccines. Collaborating with

pharma/biotech clients worldwide, Vetter supports products from preclinical development through global market supply. Through its US and European facilities, Vetter Development Service provides state-of-the-art support for early stage products, with seamless transfer at Phase III to Vetter Commercial Manufacturing for large-scale production. The company offers state-of-the-art technology and innovative processes to promote product quality and maximize API yield. For US inquiries, contact +1-847-581-6888 or infoUS@vetter-pharma.com. For Japan inquiries, contact +81-3-6717-2740 or infoAsiaPacific@vetter-pharma.com. For Asia Pacific inquiries, contact +65-6808-7766 or infoAsiaPacific@vetter-pharma.com. For EU and other international inquiries, contact +49-751-3700-0 or info@vetter-pharma.com. For more information, visit www.vetter-pharma.com.

PREMIUM COURIER & CLINICAL PACKAGER



Yourway is an integrated biopharmaceutical supply chain solutions provider offering a full range of primary and secondary clinical packaging, temperature-controlled logistics, storage and distribution services for the global pharmaceutical and biotech industries. From design through distribution, Yourway offers a full range of cost-effective clinical packaging solutions to protect your materials across the entire biopharmaceutical supply chain. Our primary and secondary packaging capabilities integrate seamlessly with our storage and distribution and premium courier services — including a full range of temperature control solutions, combined with our expansive transportation fleet, global regulatory expertise and dedicated project managers — to enhance supply chain efficiency and facilitate shorter lead times compared to other clinical services and logistics companies. For more information, contact Yourway at (888) 778-4555 or visit www.yourway.com.

DEVICE DESIGN

Autoinjector Design Adjustment to Control Needle Insertion & Initial Injection Speed – Could This Positively Impact Drug Delivery?

By: Pascal Dugand, Thomas Megard, and Séverine Duband

SELF-ADMINISTRATION & BIOLOGICS HAVE BECOME KEY DYNAMICS IN THE PARENTERAL SEGMENT

The rising prevalence of chronic diseases, requiring frequent medication, is very often combining with the growing trend of self-administration (eg, in-home care settings). In order to fit to this new mode of administration, and bring ease of use to the patients while limiting the risks, these drugs are preferably delivered in the subcutaneous tissue, being a very good match for the use of autoinjector devices.

In parallel, a majority of the new drugs in the pipelines of pharmaceutical companies are so-called “biologics.” These new biologic drugs, such as monoclonal antibodies (mAbs), are very good candidates for the treatment of the aforementioned chronic diseases. Antibodies are natural molecules of the immune system, and these molecules can be modified by biotechnological companies to obtain “biologic drugs.” Biologics have become a significant driver for new treatments, with more than 2,700 remedies in development as of mid-2017, which is three times higher than in 2013.¹ Within the top 100 products, biotechnology drugs represent 49% in 2017, and are projected to maintain a dominant position in the pharmaceutical market over the coming years as they are widely used to treat autoimmune, or inflammatory diseases as Rheumatoid Arthritis, Multiple Sclerosis, Psoriasis Arthritis, etc.²

Biological drugs are very often needed in high concentration: this can be driven by the nature of the molecule, composi-

tion of the final drug, and by the effort to decrease the frequency of treatment for the patient. Their viscosity increases as power law of the antibody concentration. Thus, to be injected, these molecules need to be diluted, which leads to higher injection volumes, and lower (but still high) viscosity. As a result, larger dose drug deliveries are a growing segment, with volume shifting toward 2 ml.

CHALLENGES OF BIOLOGICS ADMINISTRATION WITH AUTOINJECTOR DEVICES

Injecting larger volume, with high viscosity, through thinner needles, requires high injection force. It is also observed that a larger dose of viscous formulation leads to higher skin back forces. Usage of higher energy level to deliver viscous formulations could result in higher shocks on the syringe, especially at the end of syringe insertion and start of syringe emptying, and consequently increases the risk of glass syringe breakage.

Controlling the needle insertion speed can reduce the shock on the prefilled syringe. Lowering this shock will reduce the risk of glass breakage, and will allow a smooth transition to syringe emptying. Also, it was demonstrated that pressure waves generated from device actuation could lead to glass breakage.³ Reducing the syringe speed contributes to the reduction of the pressure waves, reducing then the risk of glass breakage. The mechanism of glass breakage has been thoroughly looked at, understood, and described in the literature.⁴⁻⁷

It is well known that glass has no macroscopic plasticity. It will break before the elastic limit when subjected to tensile stress. These are fragile materials. The mechanism of glass breakage is a crack propagation starting from stress concentrators. The most important stress concentrators are associated to the following:

- glass development, such as bubbles or solid inclusions
- glass forming
- impact during transfers, handling

In the case a mechanical load is applied, glass breakage might occur, originating from one of these stress concentrators. As expressed previously, glass breakage can be simply expressed as: $LOAD \times CRITICALITY \geq TOUGHNESS$.²

In order to prevent breakage, it is then required to minimize loads or flaws generation especially during handling and transport. It is generally admitted that every glass surface contains flaws. In consequence, injection device mechanism should then minimize the loads or chocks on the syringe during use.

OBJECTIVES

The objectives of this study include the following:

- to develop a calculation method for needle insertion speed and energy level transmitted to the syringe
- to use our calculation method to improve injection devices allowing

FIGURE 1

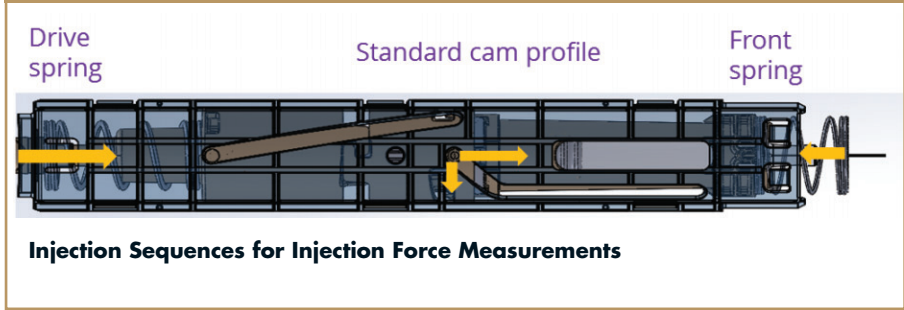

Injection Sequences for Injection Force Measurements

- smooth transition between needle insertion and syringe emptying, especially for large dose, viscous formulations, and thin needles
- to validate our calculation method and our improved injection device by experimental measurements
- Needle pusher is connected to syringe housing
- Syringe housing contains the syringe
- Front spring is connected to the front housing and the syringe housing
- Front housing is pressed by the patient for activation

CALCULATION METHOD

Our autoinjector contains the syringe with the needle and the following specific mechanical components:

- Drive Spring is connected to plunger pusher, which is connected to the needle plunger pusher

Just after activation, the spring force is pushing a specific part, the needle pusher. This needle pusher is following a cam. This cam is an adjustable path allowing needle insertion at a controlled speed. First, theoretical calculation ap-

FIGURE 2

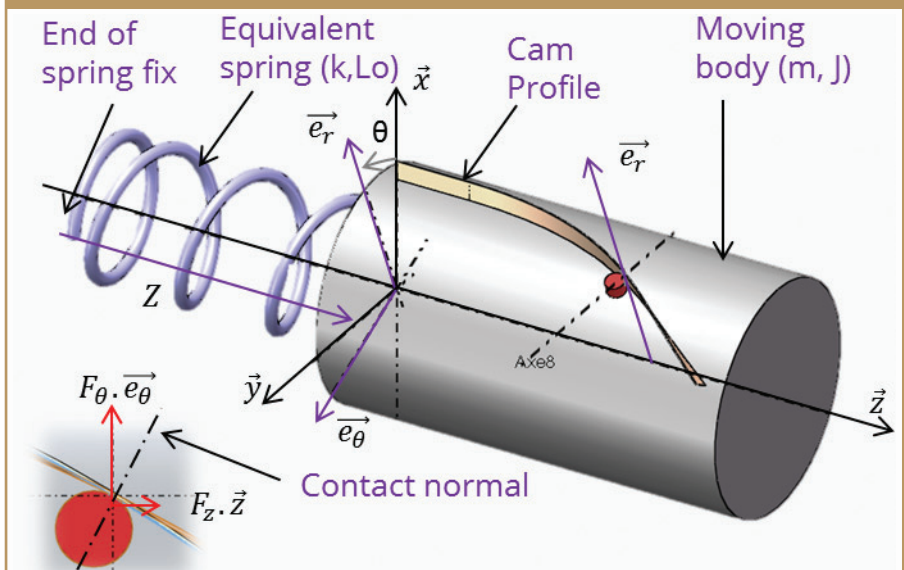

Scheme for Calculation

proach is given for a 2.25-ml syringe. Needle insertion speed, and energy transmitted to the syringe are calculated. In case of stiff spring usage, it is possible to lower the speed and energy by:

- A specific cam profile for needle insertion
- Using a counter spring back force

In our method, as highlighted hereafter, we take into account specific cam profile, drive spring, and front spring back force to calculate insertion speed and energy.

The first part of the calculation aims at predicting needle speed during insertion phase. After this phase, the spring pushes on the plunger rod and injection begins. Calculations are based on following equations: Newton's second law of motion (fundamental principle of dynamics) say that the sum of the forces $F \rightarrow$ on an object is equal to the mass m of this object multiplied by the acceleration of this object, as shown on Figure 1.

$$\begin{cases} m \cdot \frac{\partial^2 \lambda}{\partial t^2} = -z \cdot k + F_z \text{ Translation on } \vec{z} \text{ axis} & Eq_1 \\ J \cdot \frac{\partial^2 \theta}{\partial t^2} = R \cdot F_\theta \quad \text{Rotation on } \vec{z} \text{ axis:} & Eq_2 \end{cases}$$

With: J , inertia of moving body including parts in rotation; R , radius of the cam shaft; m , mass of moving body including parts in translation; k , stiffness of the equivalent spring; λ , distance from equilibria position $\lambda = (L_0 - z)$; F_z , axial contact force on the cam; F_θ , radial contact force on the cam.

Assumption: friction not taken into account. The equation of the cam gives:

$$\begin{cases} \theta(z) = f(z(t)) & Eq_3 \\ F_\theta = F_z \cdot \frac{\partial z}{R \cdot \partial \theta} & Eq_4 \end{cases}$$

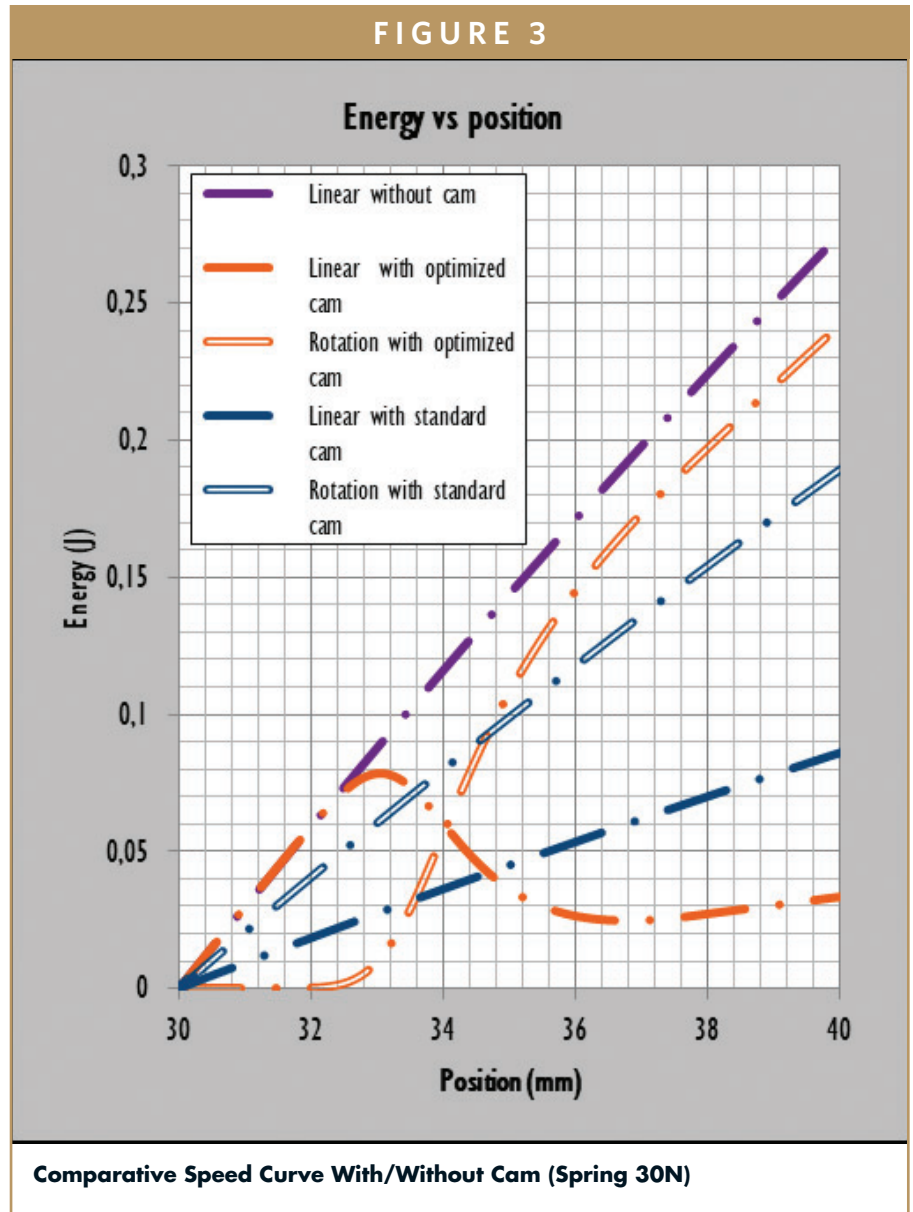

Error! Reference source not found. presents the cam profile chosen for proof of concept.

By combining the 3 previous equations:

$$m \cdot \frac{\partial^2 \lambda}{\partial t^2} = -\lambda \cdot k + J \cdot \frac{\partial^2 \theta}{\partial t^2} \cdot \frac{\partial \theta}{\partial z} \quad Eq_5 \quad (Eq_1 + Eq_2 + Eq_4)$$

The final differential equation is:

$$m \cdot \ddot{z} = J \cdot (f'(z) \cdot \dot{z} + f''(z) \cdot \dot{z}^2) \cdot f'(z) - \lambda \cdot k \quad Eq_6 \quad (Eq_5 + Eq_3)$$

Solving this differential equation by numerical calculation allows access to

axial position and axial speed at each step of needle insertion stroke. Furthermore, Energy generated by the cam ($E_{c\text{came}}$) can be calculated as the following:

$$E_{c\text{came}} = \frac{1}{2} \cdot m_s \cdot (V_{f\text{came}})^2 \quad Eq_7$$

DEVICE IMPROVEMENT

Based on our calculation method, we evaluate the influence of cam parameter on linear speed and energy, and we propose an improved configuration.

Figure 3 shows that the device with cam shows a theoretical reduction of needle speed from 4,4 m/s to 1,6 m/s at the end of insertion phase. Link to speed, we can calculate the kinetic energy of each systems as show in Figure 3. The reduction on linear speed is about 64%. The energy of the impact transmitted to the syringe is the linear kinetic energy at the end of the insertion, because the syringe is stopped just before starting injection. This kinetic energy takes the speed into account the square of linear speed.

$$\frac{E_{c_{came}}}{E_{c_{w/o\ came}}} = \left(\frac{V_{f_{came}}}{V_{f_{w/o\ came}}} \right)^2 = 0,36^2 = 13\% \quad Eq_9 \quad \left(\frac{Eq_7}{Eq_8} \right)$$

The ratio of linear speed with came on linear speed without cam is 36%. In theory, thanks to the cam, impact energy on the syringe is reduced by 87% (1%). This is a significant shock energy reduction that will reduce the risk of glass breakage especially when very stiff springs are used. Stiff springs are more and more used in autoinjectors to deliver large volume of viscous formulations, through very thin needles.

EXPERIMENTAL TESTS: OPTIMIZED SAFELIA AUTO- INJECTOR FOR VISCOUS DRUGS

Tests and comparison with theoretical calculation. Tested sample:

- 2.25 ml, 27G ½" TW

- Drive Spring characteristics 30N

FIGURE 4

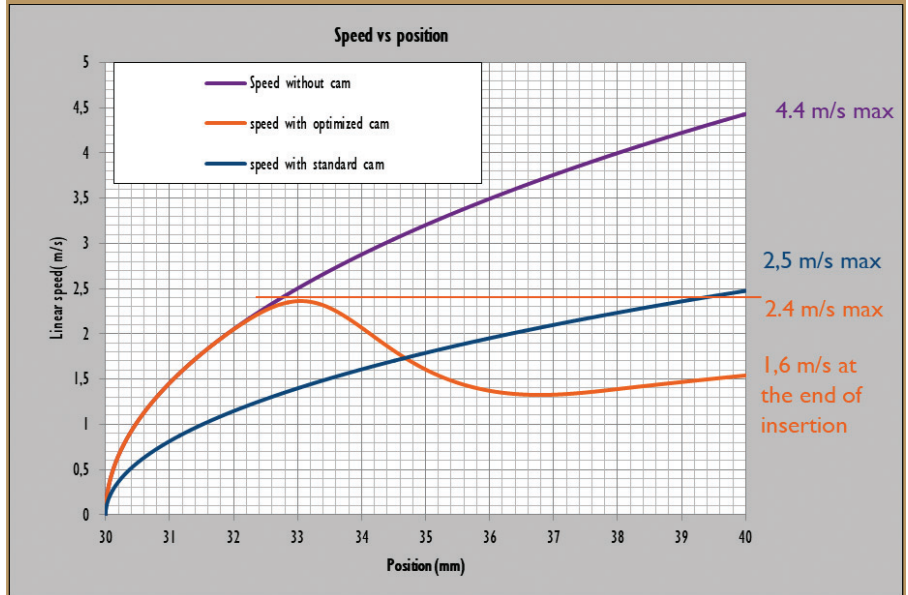

Theoretical Energy Curves With/Without Cam

FIGURE 5

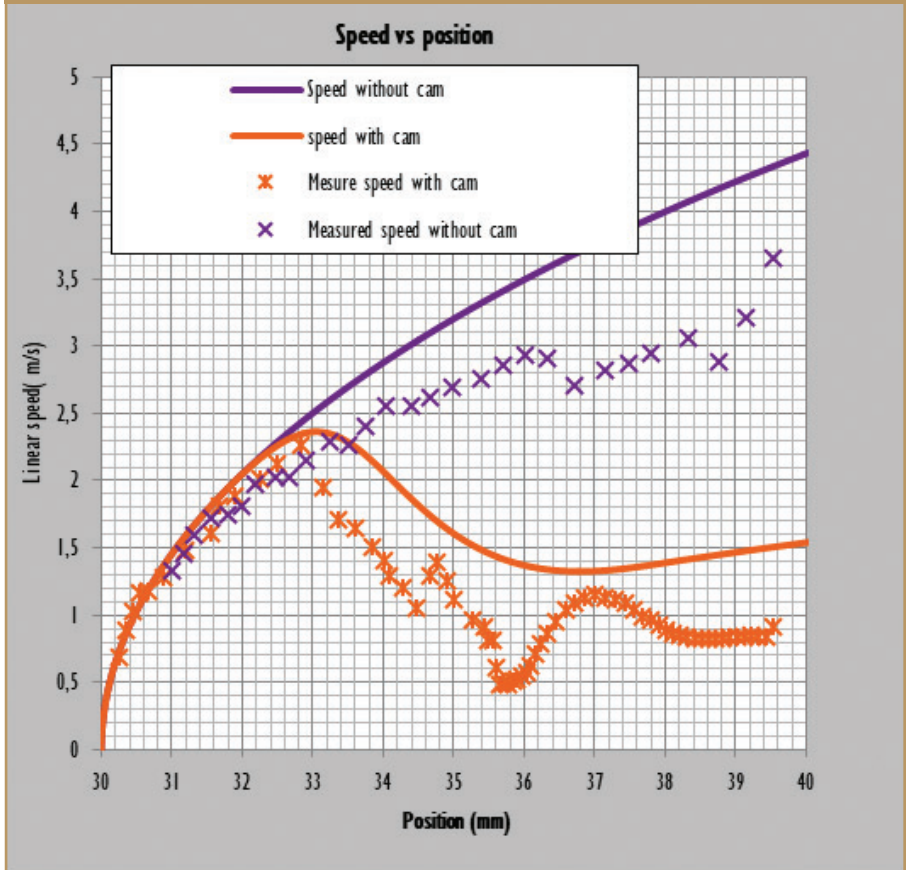

Theoretical & Practical Speed Curves With/Without Cam

Needle insertion speed was measured with a high-speed camera:

- Without cam: up to 3,5 m/s, after 10-mm stroke
- With cam: only 0,9 m/s , after 10-mm stroke

The measured reduction of linear speed is about 75% against 64% in the theoretical calculation (Figure 5).

Compared to the theoretical calculation, needle insertion speed is decreased due to friction of prototype parts, not considered in the math modeling. Without cam, jetting is observed at start of injection. This jetting can be explained by the high impact energy transmitted by the plunger rod to the plunger stopper at start of injection, once needle is inserted. With cam, jetting is not observed at start of injection. This can be explained by the lower impact energy transmitted by the plunger rod to the plunger stopper at start of injection.

REFERENCES

1. Opportunities and Challenges in Biologic Drug Delivery, Michael D. Hooven, American Pharmaceutical Review, <https://www.americanpharmaceuticalreview.com/Featured-Articles/345540-Opportunities-and-Challenges-in-Biologic-Drug-Delivery/>
2. EvaluatePharma®, World Preview 2018, Outlook to 2024.
3. Pressure and strain waves in Pre-Filled syringes during autoinjector activation - Jean-Christophe Veilleux¹ (Graduate Aerospace Laboratories, California Institute of Technology, Pasadena, CA, USA), Julian Jazayery (AMGEN, Thousand Oaks, CA, USA), Bruce Eu (Graduate Aerospace Laboratories, California Institute of Technology, Pasadena, CA, USA) and Joseph E. Shepher (AMGEN, Thousand Oaks, CA, USA), 2018-10 PDA Orlando AMGEN CALTECH oral presentation.
4. Why do Pharmaceutical Glass Containers Break: The Underestimated Power of Strength Testing and Fractography, Dr. Dan Haines (Scientific Advisor for SCHOTT pharma), Dr. Florian Maurer (Senior Scientist for Strength and Fractography at SCHOTT), Dr. Uwe Rothhaar (Director of SCHOTT pharma).
5. Fractography of Ceramics and Glasses, NIST, Special Publication 960-16 (2007), Quinn, G.D.
6. Fracture Analysis, a Basic Tool to Solve Breakage Issues, Technical Information Paper, Toshihiko Ono (Corning Japan K. K., Shizuoka Technical Center) and R. A. Allaire (Corning Incorporated, Science and Technology).
7. Défaillance de casse : l'expertise fractographique Cathie COLIN, Jean-Louis HEITZ, CRITT Matériaux Alsace

To view this issue and all back issues online, please visit www.drug-dev.com.

BIOGRAPHIES



Pascal Dugand is Technology Product Manager at Nemera. He is an experienced medical device developer engineer specialized in the development of parenteral drug delivery devices since 1990. He developed for Nemera its own IP products, including Safe'n'Sound safety device and Safelia autoinjector as well as working on several customer injectable product developments.

Thomas Megard is a Design Engineer, Abylssen for Nemera. He graduated as a Mechanical Engineer from Arts & Métiers in Cluny, France. He started to work as consultant for Abylssen since 2015. In 2017, he started as Design Engineer consultant at Nemera.



Séverine Duband is Global Category Manager at Nemera. She has more than 10 years of marketing experience with key competencies, including strategic planning, NPD launches, project management, and team leadership in an international environment. At Nemera, she particularly focuses on the range of proprietary products, including the Safelia autoinjector device.

THERANOSTICS

The Outlook for the Theranostic Radionuclide Approach to Neuroendocrine Tumors & Other Cancers

By: Eric P. Krenning, MD, PhD, and Rachel Levine

INTRODUCTION

Theranostics is a patient management strategy involving the integration of diagnostics and therapeutics. In nuclear medicine, the term “theranostics” refers to the use of specific targeting molecules labeled with either diagnostic radionuclides (eg, positron or gamma emitters) or with therapeutic radionuclides (eg, beta or alpha emitters) for diagnosis and therapy of a particular malignancy. Therefore, molecular imaging and diagnosis of the disease can be effectively followed by treatment utilizing the same targeting molecule. In practice, this concept dates back more than 50 years.¹ More recently, however, among the most successful examples of theranostics are peptide receptor scintigraphy (PRS) and peptide receptor radionuclide therapy (PRRT), also called radioligand therapy (RLT) of neuroendocrine tumors (NETs), an orphan disease. The development of these modalities through the radiolabeling of somatostatin analogs with various radionuclides has led to a revolution in patient management and established a foundation for expansion of the theranostic principle into other oncology indications.

The following provides a review of the evolution and development of theranostics, in general, citing the theranostic radionuclide approach to the management of neuroendocrine tumors to highlight this evolving modality.

THE ORIGIN OF & RATIONALE FOR THERANOSTICS

In 1941, the concept of using radioactive iodine for imaging and treatment of patients with hyperthyroidism and later thyroid

cancer was first applied by Saul Hertz.¹ His discoveries inspired the invention of some of the most successful examples of the theranostic concept in nuclear medicine, peptide receptor scintigraphy (PRS), and peptide receptor radionuclide therapy (PRRT). Through its capabilities in disease identification, targeted treatment, and monitoring, theranostics has opened a new chapter in precision medicine. Continued advancements in the field will help optimize drug efficacy and safety as well as streamline the drug development process.

THE ROLE OF PEPTIDE RECEPTORS

PRS and PRRT were primarily first used in patients with neuroendocrine tumors (NETs) in the late 1980s and early 1990s, although these acronyms were not used in literature until 1994.^{2,3}

In 1993, data on imaging using Indium-111 (In-111)-labeled pentetrotide in more than 1,000 patients were published in the *European Journal of Nuclear Medicine*.⁴ In 1994, the FDA approved In-111-pentetrotide as an imaging radiopharmaceutical, exclusively based on results achieved in approximately 350 European patients because its sensitivity and specificity in patients with gastroenteropancreatic neuroendocrine tumors (GEP-NETs) were greater than those obtained using Computed Tomography (CT) or Magnetic Resonance Imaging (MRI). In-111-pentetrotide was the first receptor-targeted, peptide-based imaging radiopharmaceutical ever approved.

Following the model of radioiodine use in thyroid cancer, patients were also treated with high doses of In-111-pentetrotide. After several years of PRRT experience with In-111-pentetrotide

FIGURE 1

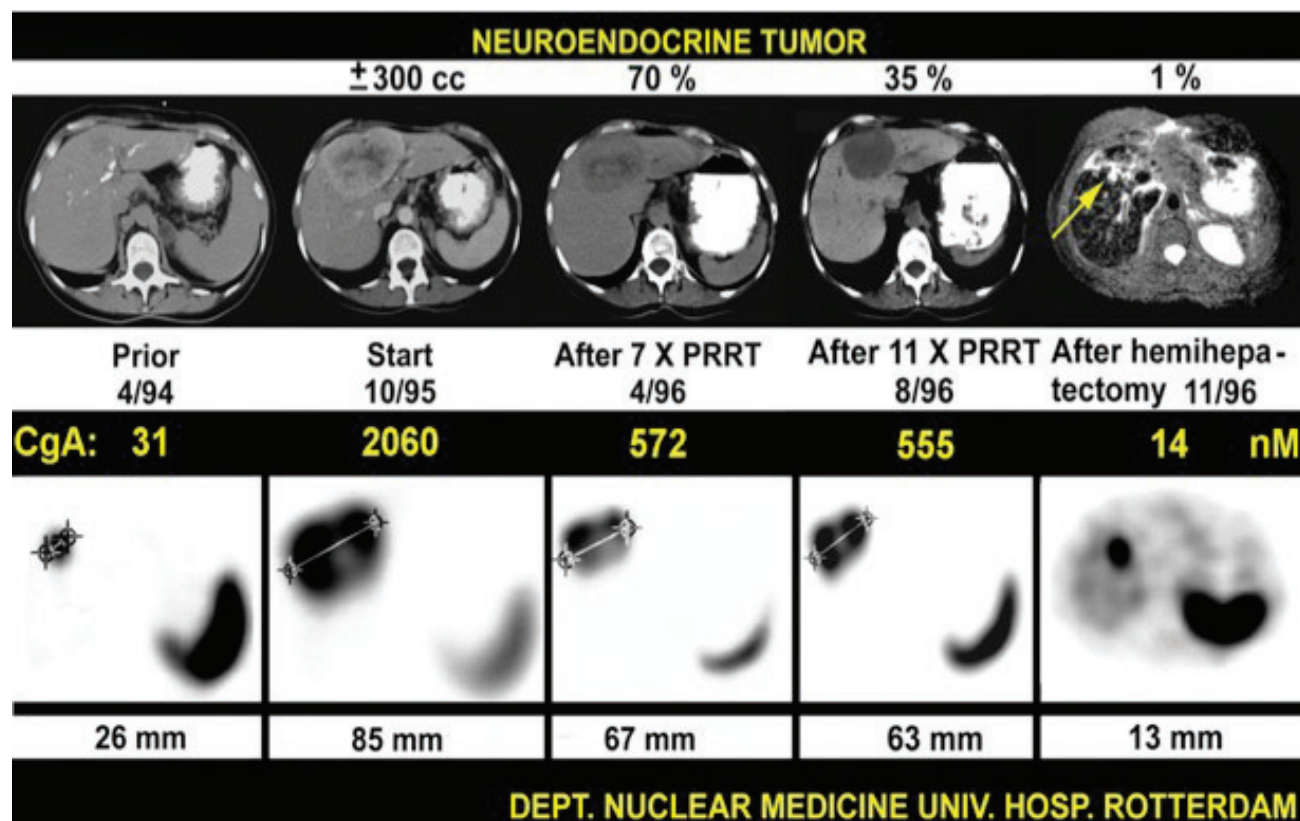

PRRT with very high doses (7.4 GBq/200 mCi per cycle) of Indium-111 pentetreotide in 1994-1996 in a patient with NET. Tumor shrinkage and tumor-marker decline (as indicated by Chromogranin A) after 11 cycles are 65% to 70% (top row), followed by a hemi-hepatectomy leaving behind a small tumor. Top and lower rows represent CT and Indium-111 pentetreotide imaging, respectively.⁵

(Figure 1), it became clear that other radionuclides, such as yttrium-90 (Y-90) or a new radionuclide, lutetium-177 (Lu-177), might be better suited for a therapeutic regimen, due to longer range of tissue penetration.⁵ In the late 1990s and early 2000s, “early adopters” of PRRT were successfully using Y-90 coupled to various somatostatin analogs. In 1998, Y-90-labeled dotatoc was used in the treatment of 10 patients with different somatostatin receptor-positive tumors.⁶ In 2001, the results of a Phase 2 study of Y-90-dotatoc in 41 patients with GEP-NETs and bronchial tumors demonstrated an overall response rate of 24% and a significant reduction in carcinoid syndrome in 83% of the patients.⁷

In 1998, a group called Specific Peptides for Imaging and Radio Isotope Ther-

apy (SPIRIT) was established to develop marketable radiopharmaceuticals using targeting peptides and peptide-like molecules to deliver diagnostic or therapeutic doses of radiation to specific sites within the body.⁸

One of the targeting peptides originating from one of the members of this group was dotatate, which was coupled with Lu-177. The first clinical studies with dotatate started in 2000 and employed a clinical protocol that later formed the basis of the NETTER-1 multinational Phase 3 trial.⁹ In 2003, a study of Lu-177 dotatate therapy in 35 patients with GEP-NETs demonstrated complete remission in 1 patient (3%), partial remission in 12 patients (35%), stable disease in 14 patients (41%), and progressive disease in 7 pa-

tients (21%), including 3 patients who died of disease-related causes during the treatment period.¹⁰

In 2010, commercial pharma stepped in and developed good manufacturing process-compliant manufacturing of Lu-177 dotatate, continued to negotiate a regulatory pathway with the US FDA and the European Medicines Agency, and a pivotal multinational Phase 3 study (NETTER-1) was started at 41 global sites in 2012.

By 2015, the NETTER-1 study had met its primary endpoint of assessing progression-free survival, demonstrating that Lu-177 dotatate significantly improved progression-free survival compared with high-dose octreotide acetate injection in patients with advanced midgut NETs.⁹ In January 2017, initial results of this Phase

FIGURE 2

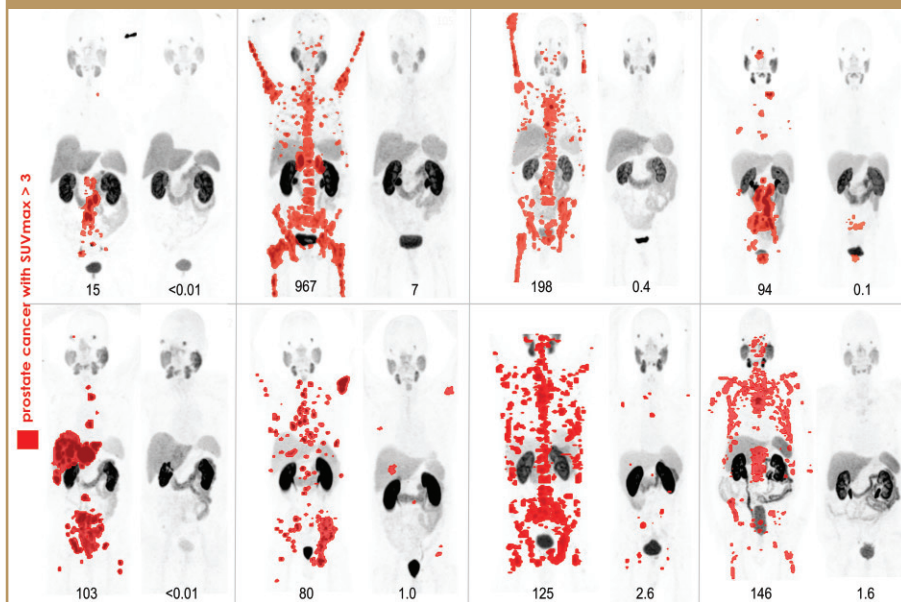

PSMA PET before and after Lu-177PSMA617 theranostic in 8 patients with metastatic prostate cancer who exhausted standard therapeutic options (Society of Nuclear Medicine and Molecular Imaging IMAGE OF THE YEAR 2018).

Ga-68-PSMA11 PET maximum intensity projection (MIP) images at baseline and 3 months after Lu-177-PSMA617 in 8 patients with PSA decline \geq 98% (see numbers, ng/ml) in a prospective Phase 2 study. Any disease with SUV over 3 is in red. Credit: Michael Hofman, John Violet, Shahneen Sandhu, Justin Ferdinandus, Amir Iravani, Grace Kong, Aravind Ravi Kumar, Tim Akhurst, Sue Ping Thang, Price Jackson, Mark Scalzo, Scott Williams and Rodney Hicks, Peter MacCallum, Cancer Centre, Melbourne, Australia.

3 trial of Lu-177 dotatate in patients with midgut NETs were published in the New England Journal of Medicine.⁹ In June 2018, additional NETTER-1 data were published in the Journal of Clinical Oncology demonstrating that treatment with Lu-177 dotatate provides clinically relevant improvement in certain symptoms and significantly longer time to deterioration in certain quality of life measures for patients with progressive midgut neuroendocrine tumors compared to octreotide LAR alone.¹⁰

CLINICAL & ECONOMIC IMPLICATIONS OF THERANOSTICS

For patients, theranostics may lead to more effective disease management, tailoring therapeutic intervention to patients who

would benefit the most, while reducing or eliminating unnecessary treatment. By selecting patients who have a higher likelihood of responding to treatments, a theranostic approach is both efficient and patient centric.

For physicians, theranostics may enhance their ability to diagnose and stage disease, select optimal therapies, and/or monitor treatment response and disease progression, improving prognostic capability for better health outcomes.

For payers, theranostic approaches can reduce costs associated with suboptimal diagnostics and treatments, and shorten the time needed to diagnose and treat patients effectively.

The theranostic model is attractive for nuclear medicine developers, as well, due to its efficiency. Only nuclear medicine presents the possibility of using the same

targeting molecule for both diagnostic and therapeutic purposes. The only difference between the two is the type of radionuclide attached to the targeting molecule – fluorine-18 (F-18), gallium-68 (Ga-68), or copper-64 (Cu-64) for diagnostic imaging, and Lu-177, Y-90, or alpha emitters for PRRT, as an example. By utilizing the same targeting molecule for both diagnostic and therapeutic drugs, developers can consolidate manufacturing (eg, synthesis and characterization) and research activities (eg, toxicology and pharmacokinetics) with one drug compound.

BRIGHT FUTURE FOR THERANOSTICS

PRS and PRRT have gained popularity among NET specialists worldwide as theranostic approaches for their patients, although until the Society of Nuclear Medicine and Molecular Imaging and the European NET Society published guidelines for their use, there were few standardized clinical practices for the administration and implementation of these procedures or the evaluation of patient progress.

US and European regulatory approvals of gallium Ga 68 dotatate and gallium (Ga 68) edotreotide, respectively, for the localization of NETs by PET/CT has already significantly changed the field of NET imaging, and US and European approvals of lutetium Lu 177 dotatate (INN: lutetium (177Lu) oxodotreotide) PRRT makes this the first nuclear medicine theranostic pairing ever approved in oncology.

Current research activities are exploring the use of this same concept for many other cancers, seeking more novel targets and targeting molecules. For example, the

investigation of radiolabeled compounds targeting prostate-specific membrane antigen (PSMA) for both diagnostic and therapeutic applications, is considered to be a milestone in the management of patients with castration-resistant prostate cancer. The observation of frequent, persistent PSMA expression in such patients has provided the rationale for the recent investigations of PSMA RLT, and there are now several such PSMA compounds in clinical development (Figure 2). Similarly, radiolabeled antagonists of gastrin-releasing peptide receptor (GRPR) have recently started clinical investigation.¹¹

Nuclear medicine, and particularly theranostics, is poised to become a key part of patient management in the future, because of its many advantages over other separate diagnostics and treatments. For NET patients, the use of agents like gallium Ga 68 dotatate and gallium (Ga 68) edotreotide, and lutetium Lu 177 dotatate can potentially facilitate patients' cancer management from initial diagnosis to therapeutic protocols and follow-up.

The nuclear medicine approach to oncology theranostics has the potential to provide value for patients, physicians, payers, and developers, based on improved targeting mechanisms, patient selection, and ability to assess treatment efficacy.

Although nuclear medicine has been around for many years, it has principally been the domain of nuclear medicine physicians and endocrinologists. However, with its applications in oncology theranostics, nuclear medicine is at a tipping point.

As with immuno-oncology – which as a concept is also not new – the advent of checkpoint inhibitors has provided medical oncologists with valuable tools and resources for cancer patient management. The theranostic approach represented by gallium Ga 68 dotatate/gallium (Ga 68) edotreotide and lutetium Lu 177 dotatate can similarly expand the scope of medical oncology and lead to a new era for nuclear medicine. ♦

REFERENCES

1. Silberstein EB. Radioiodine: the classic theranostic agent. *Semin Nucl Med.* 2012;42:164-170.
2. Krenning EP, Bakker WH, Breeman WA, et al. Localisation of endocrinerelated tumours with radioiodinated analogue of somatostatin. *Lancet.* 1989;1:242-244.
3. Krenning EP, Kooij PP, Bakker WH, et al. Radiotherapy with a radiolabeled somatostatin analogue, [¹¹¹In-DTPA-D-Phe¹]-octreotide: a case history. *Ann N Y Acad Sci.* 1994;733:496-506.
4. Krenning EP, Kwekkeboom DJ, Bakker WH, et al. Somatostatin receptor scintigraphy with [¹¹¹In-DTPA-D-Phe¹]- and [¹²³I-Tyr³]-octreotide: the Rotterdam experience with more than 1000 patients. *Eur J Nucl Med.* 1993;20:716-731.
5. Valkema R, De Jong M, Bakker WH, et al. Phase I study of peptide receptor radionuclide therapy with [¹¹¹In-DTPA]-octreotide: the Rotterdam experience. *Semin Nucl Med.* 2002;32:110-122.
6. Otte A, Mueller-Brand J, Dellas S, Nitzsche EU, Herrmann R, Maecke HR. Yttrium-90-labelled somatostatin-analogue for cancer treatment. *Lancet.* 1998;351:417-418.
7. Waldherr C, Pless M, Maecke HR, Haldemann A, Mueller-Brand J. The clinical value of [⁹⁰Y-DOTA¹]-D-Phe¹-Tyr³-octreotide [⁹⁰Y-DOTATOC] in the treatment of neuroendocrine tumours: a clinical phase II study. *Ann Oncol.* 2001;12:941-945.
8. Mallinckrodt sponsoring worldwide radiopharmaceutical collaboration with top academic researchers [press release]. Evaluate website; updated April 27, 1998. <http://www.evaluategroup.com/Universal/View.aspx?type55tory&id59348>. Accessed May 23, 2017.
9. Strosberg J, El-Haddad G, Wolin E, et al. Phase 3 trial of ¹⁷⁷Lu-Dotatate for midgut neuroendocrine tumors. *N Engl J Med.* 2017;376:125-135.
10. Strosberg J, Wolin E, Chasen B, et al. Health related quality of life in patients with progressive midgut neuroendocrine tumors treated with ¹⁷⁷Lu-Dotatate in the phase III NETTER-1 Trial. *JCO* 2018.
11. Nock BA, Kaloudi A, Lympers E, et al. Theranostic perspectives in prostate cancer with the gastrin-releasing peptide receptor antagonist NeoBOMB1: preclinical and first clinical results. *J Nucl Med.* 2017 Jan;58(1):75-80. doi: 10.2967/jnumed.116.178889. Epub 2016 Aug 4.
12. Kwekkeboom DJ, Bakker WH, Kam BL, et al. Treatment of patients with gastro-entero-pancreatic (GEP) tumours with the novel radiolabelled somatostatin analogue [¹⁷⁷Lu-DOTA(0),Tyr³]-octreotide. *Eur J Nucl Med Mol Imaging* 2003;30(3):417-22.
13. Levine R, Krenning EP. Clinical history of the theranostic radionuclide approach to neuroendocrine tumors and other types of cancer: Historical review based on an interview of Eric P. Krenning by Rachel Levine. 2017. *J Nucl Med.* 2017;58:3S-9S.

To view this issue and all back issues online, please visit www.drug-dev.com.

BIOGRAPHIES



Professor Eric P. Krenning, MD, PhD, FRCP, is emeritus professor Nuclear Medicine at Erasmus University Medical Center, Rotterdam, The Netherlands. Currently, he serves as Director, Cyclotron Rotterdam BV

situated on the campus of Erasmus University Medical Center. In 2012, Professor Krenning was awarded The EANM Honorary Membership reserved for persons of outstanding distinction practicing in the field of nuclear medicine and who provided great service or reputation to the EANM or the field of Nuclear Medicine. In 2014, he was awarded The European Neuroendocrine Tumor Society's (ENETS) Life Achievement Award in recognition of nearly 35 years of scientific research in the field of neuroendocrine tumor disease. He serves as ENETS Centers of Excellence auditor. He spent his career at Erasmus University in Rotterdam, heading the Department of Nuclear Medicine from 1985 until 2012. His main research interests include Thyroidology and Molecular Medicine with radioactive peptides for imaging and therapy. He has co-authored more than 500 peer-reviewed articles since 1975, and has been much cited and greatly respected for his contributions to better scientific practices.



Rachel Levine is the Director of Communications for Advanced Accelerator Applications, S.A., a radiopharmaceutical company specializing in nuclear medicine theranostics. She has specialized in strategic

communications for the healthcare sector (including biotech, speciality pharmaceuticals, managed care, healthcare services, and medical device and delivery) since 2000, with a primary focus on oncology. Prior to joining AAA, Rachel advised a diverse group of international companies in healthcare and other sectors as Managing Director of a global investor and public relations agency, and then as Vice President and Head of Investor Relations and Communications for a publicly traded biotechnology company.

September 2019 Advertiser Index

COMPANY	PAGE	PHONE	WEBSITE
AAPS	57		www.AAPS.org/pharmsci360
BD Medical Pharmaceutical Systems	15		www.bd.com
Captisol	5		www.Captisol.com
Catalent Pharma Solutions	76	1-888-SOLUTION	www.catalent.com/Inhalation
CPhI Worldwide	41		gotocphi.com/ddd
Credence Medsystems	7	844-263-3797	www.credencemed.com
DDL	11	800-229-4235	www.DDLtesting.com
Drug Delivery & Development	4	rvitaro@drug-dev.com	www.drug-dev.com
Drug Development Networking Summit	75	rvitaro@drug-dev.com	www.Drug-DevConference.com
Enable Injections	43		www.enableinjections.com/enfuse
Lonza Pharma & Biotech	2		www.capsugel.com
Mitsubishi Gas Chemical	3	Nb3.pharmapackaging@mgc.co.jp	www.mgc-a.com
Nemera	51	information@nemera.net	www.nemera.net
Noble	25,28		www.GoNoble.com/Solutions
PharmaCircle	37,47	1-800-439-5130	www.pharmacircle.com
PODD	53		www.theconferenceforum.org
Portal Instruments	31		www.portalinstruments.com
SHL Medical	19		www.SHL.group
Sonceboz	13		www.medical.sonceboz.com
Vetter Pharma	17		www.vetter-pharma.com
Yourway	9		www.yourway.com

Drug Development & Delivery

print
+
digital
+
events

Drug Development & Delivery is a print, digital and event provider committed to advancing the applied science, technology, and related business practices of pharmaceutical and biological drug development.

Drug Development & Delivery provides readers with an editorial environment that fosters innovation and collaboration resulting in a shorter time to market.

We report on formulation development, bioavailability and solubility enhancement, drug devices, drug delivery technologies, combination products, contract services, API manufacturing, life cycle management, business development, partnerships and collaborations.

Print & Digital Editions | Website Marketing | Newsletters | eMail Campaigns | Videos
Exclusive Online Content | Resource Directory | Webinar Production & Marketing
Custom Publishing (print & eBooks) | Custom eNewsletters | Supplier Microsites



For more information, contact:

John Kiesewetter: 541-338-0022 • jkiesewetter@drug-dev.com

Ralph Vitaro: 973-263-5476 • rvitaro@drug-dev.com

drug-dev.com



SAVE
the
DATE

5th Annual
Drug Development
Networking
Summit &
TABLE-TOP
EXHIBITION



APRIL 16, 2020
BRIDGEWATER
MARRIOTT
BRIDGEWATER, NJ



Drug Development
& Delivery

DON'T MISS OUT!
MORE TO COME
THIS SUMMER

For more information, contact Ralph Vitaro:
973-263-5476 • rvitaro@drug-dev.com

Drug-DevConference.com



25+ YEARS' EXPERIENCE
DELIVERING
END-TO-END
SOLUTIONS

100+ DEVELOPMENT,
ANALYTICAL &
MANUFACTURING
EXPERTS



end-to-end inhalation solutions. broad dose forms. reliably supplied.

FORMULATION EXPERTISE

Decades of industry-recognized experience in formulation and pre-formulation services.

DEVELOPMENT & ANALYTICAL

Wide range of capabilities from material characterization and dose form selection to process development and product testing.

FLEXIBLE MANUFACTURING

Commercial and clinical-scale production with solutions across MDIs, unit/bi-dose nasal, DPIs and Blow-Fill-Seal nebulers.



DEVELOPMENT



DELIVERY



SUPPLY

Catalent. More products. Better treatments. Reliably supplied.™

US + 1 888 SOLUTION (765-8846) EU 00800 8855 6178 catalent.com/inhalation